



**SULLIVAN  
PALATEK**

## Original installation and operating manual

EN-US



### ZL Drain 31 BI

## ■ Table of contents

1. Information on documentation.....	5
1.1 Contact .....	5
1.2 Information about this installation and operating manual .....	5
2. Safety.....	6
2.1 Use .....	6
2.1.1 Intended use.....	6
2.1.2 Reasonably foreseeable misuse.....	7
2.2 Responsibility of the operating company .....	7
2.3 Target group and personnel.....	8
2.4 Explanation of the safety symbols used.....	9
2.5 Safety instructions and warning notices.....	10
2.5.1 Basic safety instructions.....	10
2.5.2 Safe operation.....	10
2.5.3 Sudden escape of pressurized fluids .....	11
2.5.4 Electrical voltage .....	11
2.5.5 Transport and storage.....	12
2.5.6 Installation.....	12
2.5.7 Maintenance .....	13
2.5.8 Handling hazardous substances .....	13
2.5.9 Work on electronic components .....	14
2.5.10 Use of spare parts, accessories or materials .....	14
2.6 Warning notices .....	14
3. Product information .....	15
3.1 Product description.....	15
3.2 Product overview .....	15
3.3 Scope of delivery .....	15
3.4 Exploded view .....	16
3.5 Function description .....	17
3.6 Type plate .....	18
4. Technical data .....	19
4.1 Operating parameters .....	19
4.2 Storage and transportation parameters .....	20
4.3 Materials.....	20
4.4 Screw tightening torques.....	20
4.5 Dimensions.....	21
4.6 Installation dimensions.....	22
4.7 Terminal diagram .....	22
5. Transport and storage.....	23
5.1 Warning notices .....	23
5.2 Transport .....	23
5.3 Storage.....	23

<b>6. Installation</b> .....	<b>24</b>
6.1 Warning notices .....	24
6.2 Installation conditions .....	24
6.3 Installation work .....	26
<b>7. Electrical installation</b> .....	<b>28</b>
7.1 Warning notices .....	28
7.2 Connection work .....	28
7.2.1 Connecting the power supply .....	29
<b>8. Commissioning</b> .....	<b>31</b>
8.1 Warning notices .....	31
8.2 Commissioning work.....	31
<b>9. Operation</b> .....	<b>32</b>
9.1 Warning notices .....	32
9.2 Operating conditions .....	32
<b>10. Maintenance</b> .....	<b>34</b>
10.1 Warning notices .....	34
10.2 Maintenance schedule .....	34
10.3 Maintenance work .....	35
10.3.1 Service-Unit replacement.....	35
10.3.2 Function test.....	38
10.3.3 Visual inspection.....	38
10.3.4 Leak test.....	39
10.3.5 Cleaning .....	39
10.4 Warning notices .....	39
<b>11. Consumables, accessories, and spare parts</b> .....	<b>40</b>
11.1 Order information.....	40
11.2 Accessories.....	40
11.3 Spare parts.....	40
<b>12. Removal from service</b> .....	<b>41</b>
12.1 Warning notices .....	41
12.2 Removal from service .....	42
<b>13. Disassembly</b> .....	<b>43</b>
13.1 Warning notices .....	43
13.2 Disassembly work .....	43
<b>14. Disposal</b> .....	<b>45</b>
14.1 Warning notices .....	45
14.2 Disposal of operating and auxiliary materials .....	45
14.3 Disposal of components .....	45

15. Troubleshooting..... 46



16. Appendices..... 47

    16.1 Certificates..... 47

# 1. Information on documentation

This documentation describes all the steps necessary for the use and operation of the product and accessories.

## 1.1 Contact

Manufacturer	Service and tools
 <p><b>SULLIVAN PALATEK</b> AIR COMPRESSORS</p> <p>1201 West US Highway 20 Michigan City, Indiana 46360 Phone: 219.874.2497 Fax: 219.809.0203 info@palatek.com www.sullivan-palatek.com</p>	 <p><b>SULLIVAN PALATEK</b> AIR COMPRESSORS</p> <p>1201 West US Highway 20 Michigan City, Indiana 46360 Phone: 219.874.2497 Fax: 219.809.0203 info@palatek.com www.sullivan-palatek.com</p>

INFORMATION	Country specific manufacturer representation
	<p>You can contact the country-specific manufacturer's representative via the address listed in the address section on the rear cover or by using the contact form on the manufacturer's website.</p>

## 1.2 Information about this installation and operating manual

INFORMATION	Copyright protection
	<p>The contents of the installation and operating manual in the form of text, figures, illustrations, photographs, technical drawings, diagrams and other representations are protected by the copyright of the manufacturer. The distribution as well as the duplication of this document, the exploitation and the communication of its contents are prohibited unless expressly authorized.</p>

Publication date	Revision	Version	Reason for change	Scope of change
May 2024	00	00	New document	New document
January 2025	01	00	Technical changes to the product.	"4. Technical data" on page 19 "7. Electrical installation" on page 28

The installation and operating manual, hereinafter referred to as the manual, must always be kept close to the product and be in a permanently legible condition.

The manual must be handed over along with the product if it is sold or passed on.

NOTICE	Observe the manual
	<p>This manual contains all the basic information required for safe operation of the product and must be read before any actions are performed. Otherwise personal and material hazards as well as malfunction and device failure are possible.</p>

## 2. Safety

### 2.1 Use

The **ZL Drain 31 BI**, hereafter also referred to as the “product” or **ZL Drain**, is an electronically level-controlled condensate drain used to discharge condensate in pressurized systems. The **ZL Drain** discharges condensate under operating pressure without any loss of pressure.

#### 2.1.1 Intended use

Any use of this system other than the use described in this manual is hereby deemed to be non-intended and can cause a hazard for the safety of people and the environment.

The following must be noted for intended use:

- Read and follow the manual.
- Use the product and accessories indoors only.
- Only use the product and accessories within the operating parameters indicated in the “Technical data” section.
- Use the product and the accessories exclusively within the operating parameters specified in the “Technical data” section and in accordance with the agreed terms of supply.
- Only use the product and accessories with media which are free of caustic, aggressive, corrosive, toxic, flammable, oxidizing and inorganic components. In cases of doubt an analysis must be carried out.
- Only use the product and accessories in an environment where at a maximum, only splash water may occur. The splash water must be free of corrosive components.
- Only use the product and accessories in areas which are free of toxic and corrosive chemicals and gases.
- Use the product and accessories only within a pipeline system designed for the operating parameters specified in section “4. Technical data” on page 19, with appropriate connections, pipe diameters and assembly clearances.
- Only use the product and accessories outside potentially explosive atmospheres.
- Only use the product and accessories outside of areas exposed to direct sunlight and heat sources.
- Combine the product and the accessories only with the recommended manufacturer products and components indicated in this manual.
- Adhere to the prescribed maintenance schedule.

Before using the product and the accessories, the operating company must make sure that all conditions and prerequisites for intended use are given.

The product and the accessories have been exclusively designed for stationary use in a commercial or industrial area. All of the assembly, installation, operation, maintenance, disassembly and disposal work described may only be performed by qualified skilled technical personnel.

## 2.1.2 Reasonably foreseeable misuse

Reasonably foreseeable misuse is deemed to have occurred if the product or the accessories are used in any other way than that described in the section “Intended use”. Reasonably foreseeable inappropriate use includes the use of the product or the accessories in a manner not intended by the manufacturer or supplier but which may result from foreseeable human behavior.

Reasonably foreseeable inappropriate use includes:

- The execution of any kind of modification, in particular constructive and process-technology related interventions.
- The suspension, bridging or non-application of existing or recommended safety equipment.
- Using the product and the accessories in systems that use carbon dioxide as an operating medium.

This list is not exhaustive as not all possible inappropriate use can be foreseen in advance. If the operating company is aware of any inappropriate use of the product or accessories which are not listed here, the manufacturer must be informed immediately.

## 2.2 Responsibility of the operating company

The responsible operating company must ensure the following to prevent accidents, incidents and adverse effects on the environment:

- Before all actions, check to ensure that the manual available does in fact belong to the product.
- The product and the accessories are used, serviced and repaired in accordance with the intended use.
- The product and accessories are only used with the recommended and fully operable safety equipment.
- All assembly, installation and maintenance work is carried out by qualified skilled technical personnel only.
- Personnel have the necessary personal protective equipment available and also use this equipment.
- Suitable technical safety measures are taken so that the permissible operating parameters are adhered to.
- Keep all safety labels and the type plate on the product in legible condition. Replace damaged and illegible markings immediately.

## 2.3 Target group and personnel

This manual addresses the personnel listed below who are involved with work on the product or the accessories.

INFORMATION	Personnel requirements
	<ul style="list-style-type: none"> <li>• Minors are strictly prohibited from working with and on the product and its accessories.</li> <li>• The personnel may not execute any actions on the product or the accessories when they are under the influence of drugs, medications, alcohol or other substances that may impair their consciousness.</li> </ul>

### Operating personnel

Operating personnel are persons who are able to safely operate the product and accessories through their knowledge of the manual and through instruction on the product and accessories. Operating personnel can recognize possible malfunctions and dangerous situations independently and arrange for corresponding measures.

### Skilled technical personnel specialized in transportation and storage

Skilled technical personnel - transport and storage are people who, due to their training, professional experience and qualifications, have all the necessary skills to safely execute all actions in connection with the transport and storage of the product, to instruct, to recognize possible dangerous situations independently and to execute measures to avoid danger.

The skills required include, in particular, experience operating hoists, forklifts and lifting equipment and familiarity with locally applicable laws, standards and guidelines relating to transport and storage.

### Skilled technical personnel specialized in pressure equipment and systems

Skilled technical personnel specializing in pressure equipment and systems consists of people who, as a result of their training, professional experience and qualifications, have all the necessary capabilities to safely carry out and order all activities related to pressurized fluids and systems, to independently identify potentially hazardous situations, and to implement appropriate measures to avert any danger.

These skills especially include experience with the use of measuring and control equipment, as well as familiarity with all locally applicable regulations, standards, and directives for pressurized systems.

### Trained electricians

"Trained electricians" refers to personnel whose training, work experience, and qualifications have provided them with all the skills necessary to safely carry out and direct any work involving electricity, identify potential hazards independently, and take measures to prevent those hazards.

These skills especially include experience with the use of electrical systems and measuring and control equipment, as well as familiarity with all regionally applicable regulations, standards, and directives for electrical and electronic equipment.









### Qualified service technicians

Qualified service technicians are persons who have the skills and qualifications as defined in all the aforementioned definitions concerning skilled technical personnel. Qualified service technicians must be verifiably trained and authorized for all work on the product.



## 2.4 Explanation of the safety symbols used

The symbols used below indicate safety-relevant and important information which must be adhered to when handling the product and to ensure safe and optimum operation.

Symbol	Description / explanation
	General warning symbol (danger, warning, caution)
	Pressurized system warning
	Hazardous voltage warning
	Read and follow the installation and operating manual
	General instruction symbol
	Wear safety footwear
	Use protective gloves (cut-proof and liquid-resistant)
	Wear safety goggles with side shields
	General information

## 2.5 Safety instructions and warning notices

This section provides an overview of all the important safety aspects for personal protection as well as for the safe and problem-free operation of the product and accessories.

The following sections list the dangers posed by this product and the accessories even with intended use. To minimize the risk of personal injury and property damage and to avoid dangerous situations, observe the safety instructions listed and adhere to the warning notices in the other sections of this manual.

Basic warning notices and the necessary qualifications of skilled technical personnel are always listed at the beginning of the section in the "Warning notices" section.

Warning notices related to specific actions are printed directly before potentially hazardous procedures or sequences of actions.

As well as causing personal injury, failure to observe safety instructions and warning notices may result in malfunctions, disruption to operations, and property damage.

### 2.5.1 Basic safety instructions

- Before starting work, refer to the technical documentation for the entire system and observe the overall operating instructions.
- Carry out a risk assessment before starting work on site (last minute risk assessment).
- Use suitable personal protective equipment for all work.
- Set up a safety area around the working area during all installation, maintenance and repair work.
- Use existing system-specific protection procedures (e.g., LOTO procedure) to safely de-energize and isolate the system or system sections.

### 2.5.2 Safe operation

The following actions may result in serious injury or death:

- Commissioning and operation of the product and accessories outside the permissible limit values and operating parameters
- Unauthorized interference and unauthorized modifications of the product and accessories

To guarantee the safe operation of the product and accessories, observe the following:

- Observe the limits and operating parameters specified on the type plate and in the manual.
- Check whether the permissible operating parameters have been changed or restricted by the use of accessories.
- Observe the installation conditions and the ambient conditions.
- Adhere to the maintenance intervals.

## 2.5.3 Sudden escape of pressurized fluids

The following situations may result in serious injury or death:

- Contact with fast or suddenly escaping fluids
- Bursting system components
- Whipping of pressurized hoses and pipes

For the safe handling of pressurized systems, observe the following:

- Observe the following safety rules during all work:
  1. Shut down the system or system section.
  2. Secure the system or system section against restarting.
  3. Reduce the pressure in the system or all system sections to the ambient pressure.  
e.g. by slowly releasing the pressure in a controlled manner via relief valves
  4. Lock out and tag out the system or system section so that it cannot be pressurized again.
- Check the pressurized system or system section for safety, contamination and possible damage.
- Before pressurization, check all system connections for leak tightness and tighten if necessary.
- Make absolutely sure to charge the system or system section with pressure slowly.
- Avoid pressure blows and high differential pressures.
- Compensate any vibrations occurring in the pipe network by using vibration dampers.

## 2.5.4 Electrical voltage

Contact with live components may result in serious personal injury or death.

In order to safely handle live components, make sure to observe the following:

- Connect the product and accessories to the power supply only if they are in proper working order.
- Comply with all locally applicable legal requirements and regulations during installation.
- The power supply must have a disconnect device that is easily accessible in the proximity of the product.  
→ This disconnect device must disconnect all live cables.
- Only operate the product and accessories with a complete and closed cover, closed electronic housing, or closed control cabinet.
- Before starting work on the product:
  1. De-energize and isolate  
→ Disconnect the product from all poles on all sides
  2. Lock and tag out
  3. Check to make sure that the product is completely de-energized  
→ Use a suitable and approved measuring device (e.g., twin lead tester)
  4. Ground and short circuit

## 2.5.5 Transport and storage

Improper transportation and improper storage may result in personal injury or property damage.

In order to ensure safety during the transport and storage of the product and accessories, observe the following:

- Use personal protective equipment for all work with packaging material.
- Handle packaging, the product and accessories carefully.
- Transport and handle the product and accessories according to the markings on the packaging.
- Use only proper transportation, lifting and lashing equipment that is in proper working order.
- Use only transportation, lifting and lashing equipment that are rated for the total weight of the product.
- Always adhere to the permissible transport and storage parameters.
- Store the product and accessories only outside of areas exposed to direct sunlight and heat sources.

## 2.5.6 Installation

Improper physical or electrical installation of the product and accessories may result in personal injury and property damage as well as impair operation.

For safe physical and electrical installation, observe the following:

- Install the product, the accessories, and all parts and materials used so that they are not subject to mechanical tension.
- Check all plug-type connections for a correct fit.
- Avoid a stumbling hazard by routing cables and hoses accordingly.
- Avoid mechanical stress on the cables.
- Fix and fasten hoses in such a way that they cannot flap around.
- Hard-pipe the inlet lines.

## 2.5.7 Maintenance

Improper performance of maintenance and repair work can result in serious injury or death.

For safe maintenance and repairs, observe the following:

- Before starting work, depressurize the pressurized product and accessories and secure them against unintentional pressurization.
- Before starting work, isolate the product and accessories from the power source and secure them against being switched back on again unintentionally.
- Only use materials approved for the respective application.
- Use only suitable tools that are in proper working order.
- Only use cleaned pipes and hoses that are free of dirt and corrosion.
- Never use abrasive or aggressive cleaning agents or solvents which could damage the outer coating (e.g. markings, type plate, corrosion protection, etc.).
- Never clean the device with hard or pointed implements.
- Use only the specified materials and media for cleaning.
- Observe statutory, local and in-house hygiene regulations.
- Pay attention to order and cleanliness during maintenance and repair work. Prevent contamination from entering the opened product or accessories. Store disassembled components and accessories directly in a safe place.
- After completing maintenance and repair work, remove all tools and cleaning agents used, as well as all parts that are no longer needed, from the work area.
- Only dispose of the product and accessories when cleaned and freed of any residue.
- Dispose of all components, parts, operating and auxiliary materials as well as cleaning agents professionally and in accordance with all locally applicable legal requirements and regulations.
- Dispose of electrical and electronic components through a specialized disposal company or return them to the manufacturer.

## 2.5.8 Handling hazardous substances

Contact with condensate containing substances which endanger health and the environment can pose a health hazard, causing irritation and/or damage to the eyes, skin and mucous membranes. In addition, polluted condensate must be prevented from entering the sewerage system, waters or the ground.

For the safe handling of polluted condensate, observe the following:

- Use suitable protective equipment when handling condensate.
- Collect and dispose of any leaking or spilled condensate in accordance with locally applicable legal requirements and regulations.

### 2.5.9 Work on electronic components

Electrostatic discharge (ESD) can cause damage to electronic components and result in malfunctions, operational disruptions, and property damage.

- Take proper measures to prevent electrostatic discharge (e.g., grounding, equipotential bonding, anti-static mats, etc.).

### 2.5.10 Use of spare parts, accessories or materials

The use of incorrect spare parts, accessories or materials, as well as auxiliary and operating materials, may result in death or serious injury. Malfunction and device failure as well as material damage can occur.

- Only use undamaged original parts, auxiliary and operating materials which are specified by the manufacturer to complete all work.
- Only use the materials approved for the respective application and suitable tools in proper working order.
- Only use cleaned pipes that are free of dirt and corrosion.
- Only use electric components and materials that comply with locally applicable legal requirements and regulations (standards, directives, etc.) for electrical safety.

## 2.6 Warning notices

Warning notices warn against dangers when handling the product and accessories.

Failure to observe warning notices may result in personal injury, damage to property, and impairment to operations.

#### Structural set up:

SIGNAL WORD	Type and source of danger
 Symbol	Possible consequences if the danger is ignored
	<ul style="list-style-type: none"> <li>• Measures to prevent the danger</li> </ul>

#### Signal words:

<b>DANGER</b>	<b>Imminent hazard</b> Consequences of non-compliance: Death or serious personal injury
<b>WARNING</b>	<b>Imminent hazard</b> Consequences of non-compliance: Death or serious personal injury are possible
<b>CAUTION</b>	<b>Potential hazard</b> Consequences of non-compliance: Personal injury or damage to property are possible
<b>NOTICE</b>	<b>Additional information</b> Consequences of non-compliance: Damage to property, malfunction and device failure are possible. No hazard to people or endangerment of safe operation.

## 3. Product information

### 3.1 Product description

The **ZL Drain** is an electronically level-controlled condensate drain used to discharge condensate in pressurized systems. The **ZL Drain** discharges condensate under operating pressure without any loss of pressure.

### 3.2 Product overview

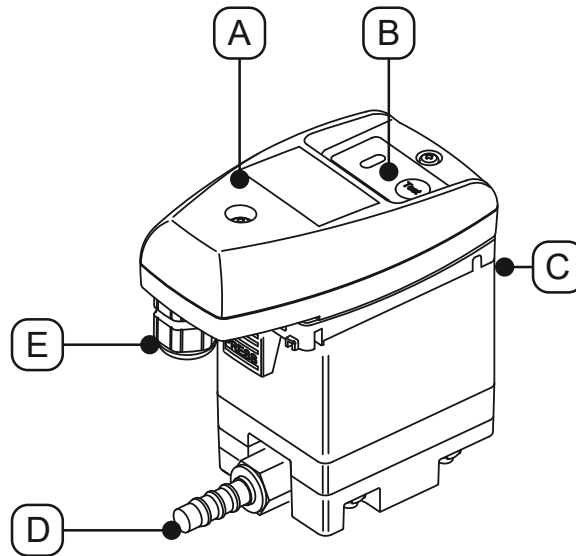



Pos. No.	Description / explanation
[A]	Complete control unit
[B]	Control panel
[C]	Condensate inlet

Pos. No.	Description / explanation
[D]	Condensate outlet
[E]	Cable fitting

### 3.3 Scope of delivery

The following table shows the parts included with the product:

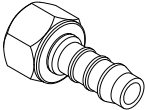
Figure	Description / explanation
	<b>ZL Drain 31 BI</b>
	Original installation and operating manual
	One (1) barbed hose fitting

### 3.4 Exploded view

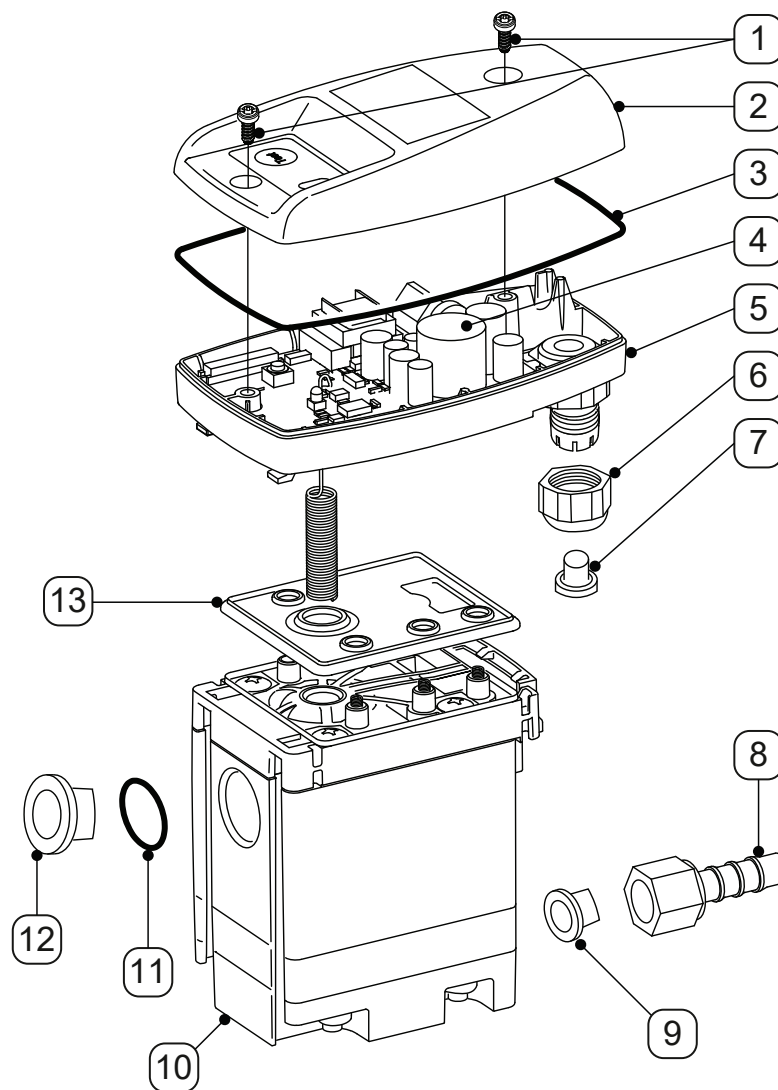

Pos. No.	Description / explanation
[1]	3.5 x 10 mm screw
[2]	Top cover
[3]	Gasket
[4]	Sensor board
[5]	Bottom cover
[6]	Fitting
[7]	Plug

Pos. No.	Description / explanation
[8]	Barbed hose fitting
[9]	Tapered plug
[10]	Service-Unit
[11]	O-ring 20 x 2 mm
[12]	G1/2" plug
[13]	Sealing mat

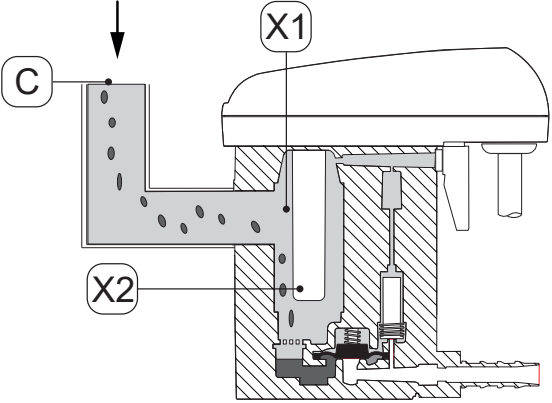
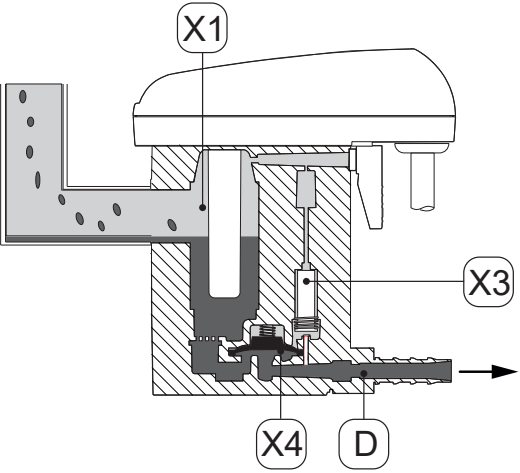
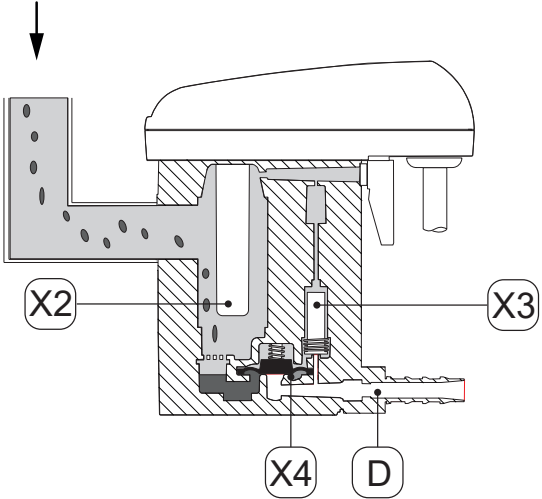

### 3.5 Function description

Figure	Description / explanation
	<p>The condensate flows through the condensate inlet [C] into the ZL Drain and collects in the housing [X1].</p> <p>The fill level in the housing [X1] is continuously monitored by a capacitive sensor in the sensor tube [X2].</p>
	<p>As soon as the condensate has reached the maximum fill level, the pilot valve [X3] is switched via the control system.</p> <p>The pilot valve [X3] switches and the area above the membrane [X4] is vented.</p> <p>The membrane [X4] lifts off the valve seat and the positive pressure in the housing [X1] forces the condensate into the condensate outlet [D].</p>
	<p>When the sensor in the sensor tube [X2] is no longer covered by condensate, the control system actuates the pilot valve [X3] and pressure builds up above the membrane [X4].</p> <p>The membrane [X4] is pressed onto the valve seat and the condensate outlet [E] is tightly sealed.</p>

### 3.6 Type plate

The type plate, which contains identification information and operating parameters for the product, is located on the bottom cover.

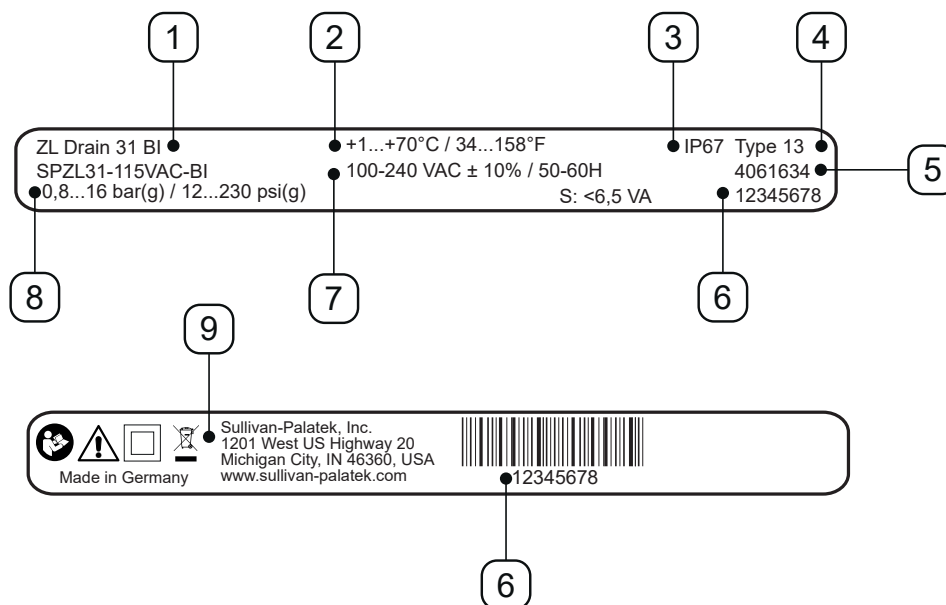

Example image

Pos. No.	Description / explanation
[1]	Product designation
[2]	Operating temperature
[3]	IP degree of protection
[4]	Enclosure rating
[5]	Material number
[6]	Serial number
[7]	Operating voltage
[8]	Operating pressure
[9]	Protection class II
[10]	Manufacturer

For more information, refer to section “2.4 Explanation of the safety symbols used” on page 9.

## 4. Technical data

### 4.1 Operating parameters

ZL Drain	31 BI
Relative ambient humidity	≤10 ... 80 %, without condensation
Maximum operating altitude	3000 m 3280.84 y
Minimum / maximum operating pressure	0.8 ... 16 bar(g) 12 ... 230 psi(g)
Minimum / maximum operating temperature	+1 ... 70 °C +34 ... +158 °F
Average discharge rate	0.63 l/h 0.17 gal/h
Maximum discharge rate (short-term)	5.5 l/h 1.45 gal/h
Condensate inlet port*	One (1) NPT1/2", female, maximum screw-in depth: 13.5 mm (1/2 in)
Condensate outlet port	One (1) G1/4", male, barbed hose fitting for inside hose diameter of 8 ... 10 mm (0.31 ... 0.39 in)
Media	Condensate, oily or oil-free
Empty weight	0.6 kg 1.32 lbs
Operating voltage	100 ... 240 VAC ±10% (50 ... 60 Hz) or 24 VAC -10%/+20% (50 ... 60 Hz) or 24 VDC -10%/+20% (see type plate)
Power consumption	6.5 ... 8 VA
Protection class	IP67
Enclosure rating	Type 13
Overvoltage category (IEC 61010-1)	II
Pollution degree (IEC 61010-1)	2
Recommended cable diameter	5 ... 10 mm 0.23 ... 0.33 in
Recommended wire cross-sectional area / wire gauge	0.75 ... 1.5 mm <sup>2</sup> AWG 14 ... 20

\* G thread version is available as an option.

## 4.2 Storage and transportation parameters

ZL Drain	31 BI
Minimum / maximum temperature for storage and transportation	+1 ... +70 °C +34 ... +158 °F

## 4.3 Materials

ZL Drain	31 BI
Housing	Aluminum and plastic, glass fiber reinforced
Membrane	FKM

## 4.4 Screw tightening torques

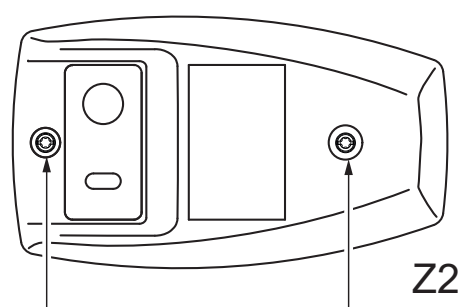
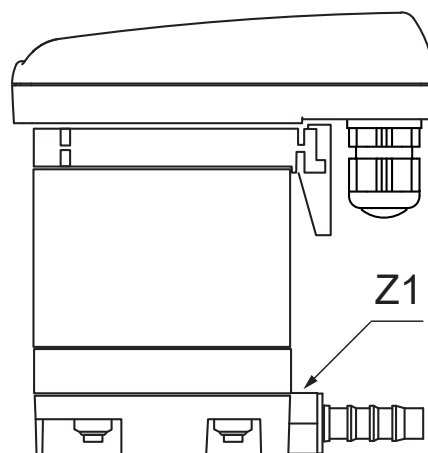

Pos. No.	Description / explanation	Tightening torques
[Z1]	Barbed hose fitting, condensate outlet	3 ... 4 Nm (2.21 ... 2.95 ft-lb)
[Z2]	Screws, top cover	0.9 Nm +0.5 Nm (0.66 ft-lb +0.37 ft-lb)

### 4.5 Dimensions

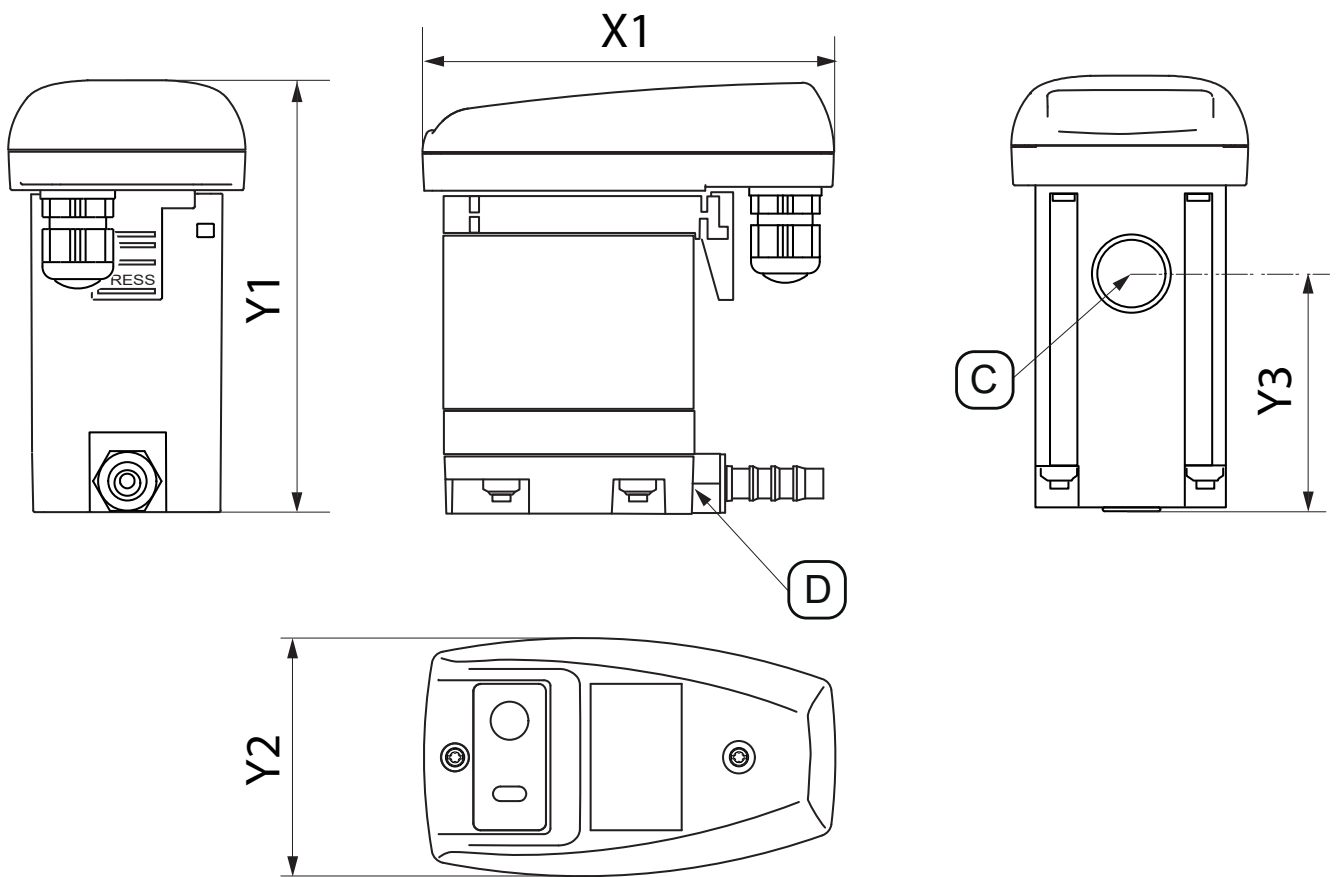

Pos. No.	ZL Drain 31 BI
[X1]	113 mm 4.45 in
[Y1]	118 mm 4.65 in
[Y2]	65 mm 2.56 in
[Y3]	62.5 mm 2.46 in
[C] - Condensate inlet port	NPT1/2" (G 1/2")
[D] - Condensate outlet port	G1/4" Ø 8-10 (dia 0.32 - 0.39)

### 4.6 Installation dimensions

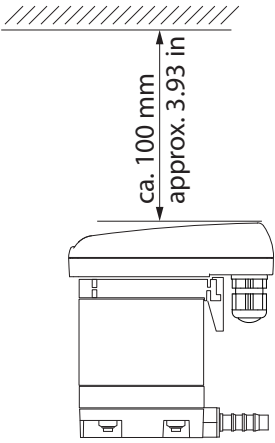

Figure	Description / explanation
	<p>During installation, leave sufficient mounting space above the top cover so that the LEDs are visible and the TEST button can be actuated.</p>

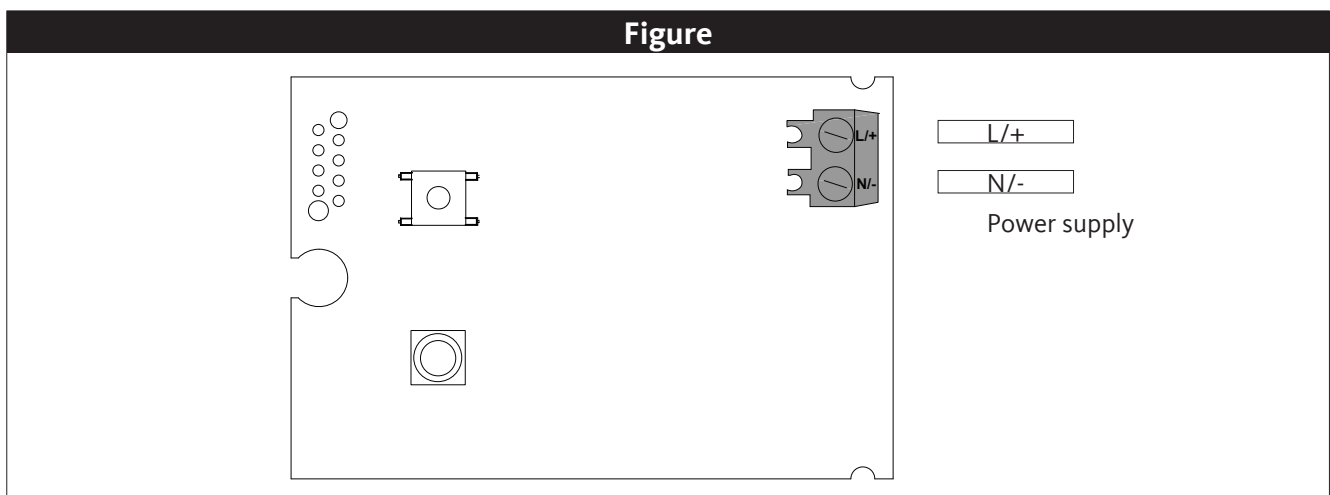
### 4.7 Terminal diagram



## 5. Transport and storage

### 5.1 Warning notices

<b>Personnel</b>	
Skilled technical personnel - transport and storage (see section "2.3 Target group and personnel" on page 8)	
<b>CAUTION</b>	<b>Improper transportation or storage</b>
	<p>Improper transportation or storage may result in personal injury.</p> <ul style="list-style-type: none"> <li>• Use personal protective equipment for all work with packaging material.</li> <li>• Handle packaging, the product and accessories carefully.</li> <li>• Use only proper transportation, lifting and lashing equipment that is in proper working order.</li> <li>• Use only transportation, lifting and lashing equipment that are rated for the total weight of the product.</li> <li>• Always adhere to the permissible transport and storage parameters.</li> </ul>
<b>NOTICE</b>	<b>Handling packaging materials</b>
	<p>Improper disposal of packaging materials can cause environmental damage.</p> <ul style="list-style-type: none"> <li>• Dispose of the packaging material in accordance with the applicable legal requirements and regulations of the country and place of use.</li> </ul>

### 5.2 Transport

Check the product after transport and after removing the packaging material for possible transit damage. If you detect any such damage, immediately notify the carrier company and the manufacturer or one of its agents.

Transport the product as follows:

- Only transport the product in its original packaging.
- Handle the packaging and the product carefully.
- Observe the shipping weight information and all labels and markings on the packaging.
- Secure the packaging and the product in such a way that they will not slip or fall during transportation.
- Pack all parts impact-proof using suitable material.

### 5.3 Storage

Store the product and accessories as follows:

- Observe the storage parameters in section "4.2 Storage and transportation parameters" on page 20.
- Store in a closed, dry, and frost-free room.
- Store away from outdoor weather conditions, direct sunlight, and heat sources.
- Secure against falling over and protect against vibrations at the storage location.

## 6. Installation

### 6.1 Warning notices

Personnel	
Skilled technical personnel - pressure equipment and systems (see section "2.3 Target group and personnel" on page 8)	

DANGER	Sudden escape of pressurized fluids
	<p>There is a danger of death or serious personal injury resulting from contact with fast or suddenly escaping fluids or through bursting system parts.</p> <ul style="list-style-type: none"> <li>• Before starting work, depressurize the pressurized system and secure it against unintentional pressurization.</li> <li>• Assemble all pipes and hoses free of mechanical stress.</li> </ul>

### 6.2 Installation conditions

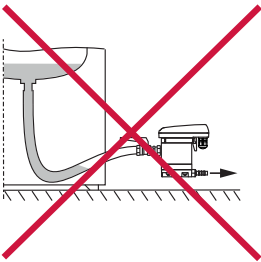
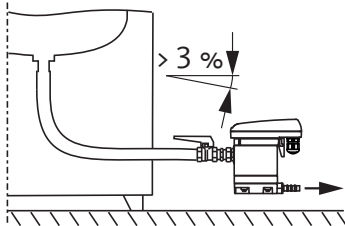
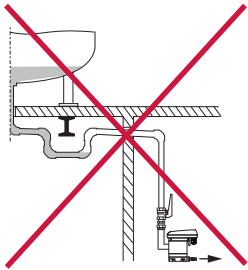
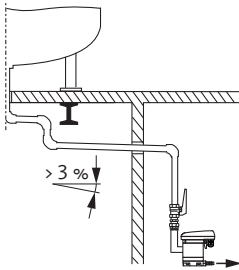
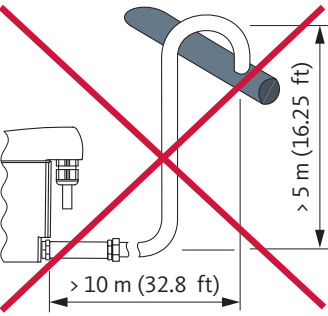
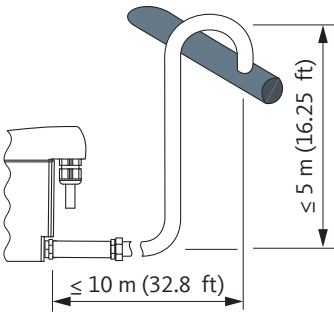
Wrong	Correct	Description / explanation
		<p><b>Continuous slope &gt; 3% in hose lines</b></p> <ul style="list-style-type: none"> <li>• Ensure a continuous slope &gt; 3% when using hoses as inlet lines.</li> <li>• Make sure that no water pockets form.</li> </ul>
		<p><b>Continuous slope &gt; 3% in pipe lines</b></p> <ul style="list-style-type: none"> <li>• Ensure a continuous slope of &gt; 3% when routing the inlet lines.</li> <li>• Make sure that no water pockets form.</li> </ul>
		<p><b>Drain line characteristics</b></p> <ul style="list-style-type: none"> <li>• Do not use shut-off valves in the drain line.</li> <li>• Connect the <b>ZL Drain</b> only with a hose to the drain line.                             <ul style="list-style-type: none"> <li>→ The hose will compensate for assembly tolerances, vibrations, and thermal expansion.</li> </ul> </li> <li>• Do not install the drain line in storage or transit areas.</li> <li>• The drain line must not exceed a maximum length of 10 m (32.8 ft) or have an upward slope for more than 5 m (16.25 ft).                             <ul style="list-style-type: none"> <li>→ The minimum operating pressure increases by 0.1 bar(g) (1.5 psi(g)) for each meter of upward slope.</li> </ul> </li> </ul>

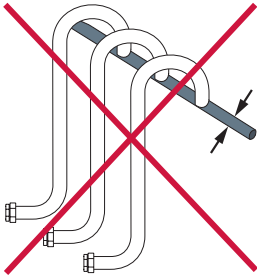
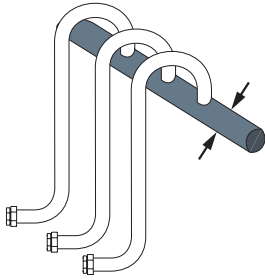
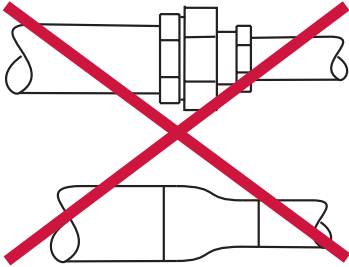
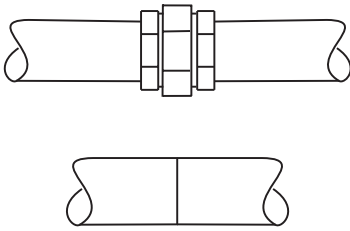
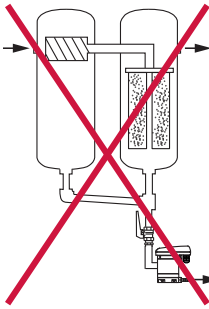
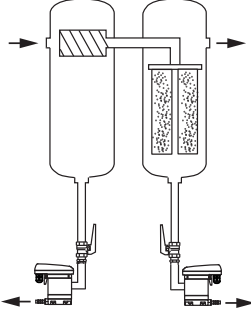
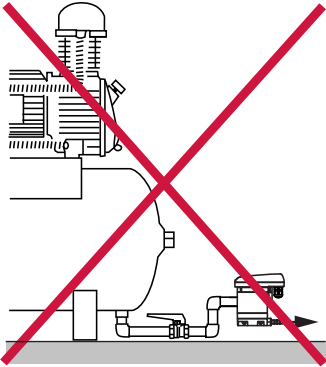
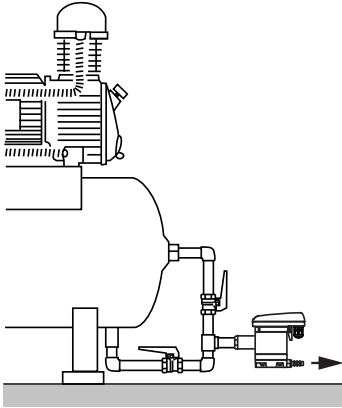
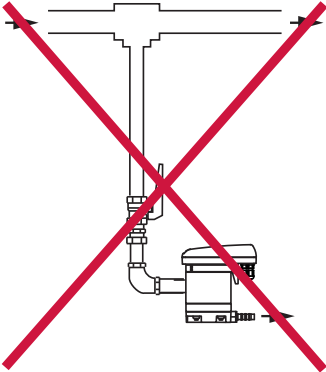
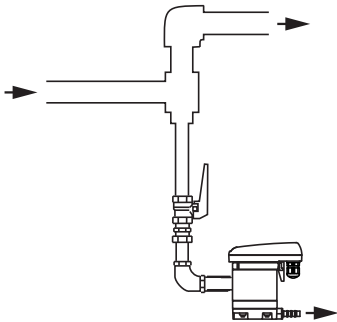

Wrong	Correct	Description / explanation
		<p><b>Collecting line characteristics</b></p> <ul style="list-style-type: none"> <li>The cross-sectional area of the collecting lines must be at least equal to the sum of the individual cross-sectional areas of the connected inlet lines.</li> <li>Route the collecting line with a continuous downward slope &gt; 3%.</li> </ul>
		<p><b>Maintain the minimum pipe diameter</b></p> <ul style="list-style-type: none"> <li>The minimum inner diameter for the inlet line and the drain line is 13 mm (0.5 in).</li> <li>Do not constrict or reduce the (minimum) pipe diameter with reducers (reducing nipples).</li> </ul>
		<p><b>Bypassing filters</b></p> <ul style="list-style-type: none"> <li>Drain each condensate accumulation point separately with a <b>ZL Drain</b>.</li> <li>Make sure not to use any routing that creates a filter bypass path.</li> </ul>
		<p><b>Ensure proper venting</b></p> <ul style="list-style-type: none"> <li>In the event of insufficient slope in the inlet or other inlet problems, install a vent line.</li> </ul>
		<p><b>Discharge from pressurized pipelines</b></p> <ul style="list-style-type: none"> <li>Redirect the gas stream in order to create a deflecting surface so that the liquid components in the gas will be drained.</li> </ul>

### 6.3 Installation work

For installation work to be carried out, the following prerequisites must be fulfilled and the preparatory tasks must have been completed.

Prerequisites		
Tools	Material	Protective equipment
<ul style="list-style-type: none"> <li>Open-end wrench or adjustable wrench</li> </ul>	<ul style="list-style-type: none"> <li>Sealing materials (e.g., Teflon tape)</li> <li>Inlet line</li> <li>Drain line</li> <li>Hose, inner diameter of 8 to 10 mm (0.31 to 0.39 in), approx. length of 30 cm (1 ft)</li> </ul>	<p><b>To be worn at all times:</b></p> 

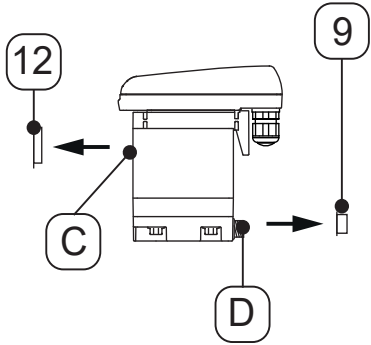
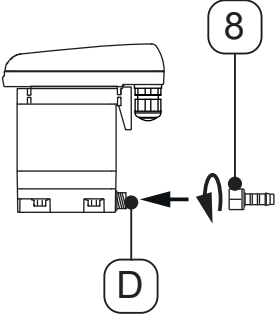

Preparatory work	
1.	Depressurize the pressurized system or the corresponding system section and secure it against unintentional pressurization.
2.	Have the hose and hose clamp for connecting to the condensate outlet ready.

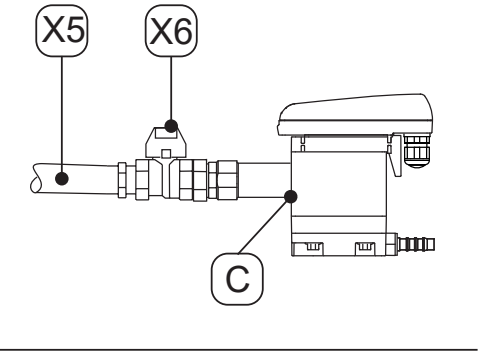
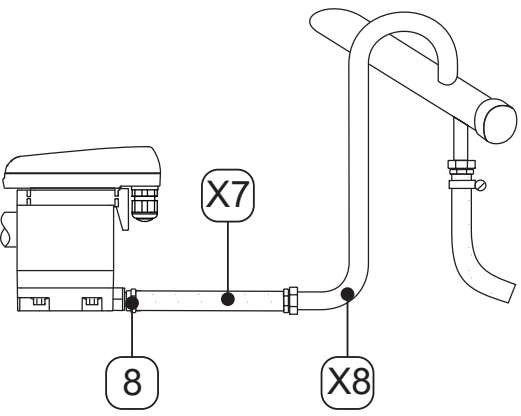
Installation work	
Figure	Description / explanation
	<ol style="list-style-type: none"> <li>Remove the plugs <b>[9, 12]</b> from the condensate inlet <b>[C]</b> and condensate outlet <b>[D]</b>.</li> </ol>
	<ol style="list-style-type: none"> <li>Screw the provided barbed hose fitting <b>[8]</b> onto the condensate outlet <b>[D]</b>.</li> <li>Tighten the barbed hose fitting <b>[8]</b> with a torque of 3 ... 4 Nm (2.21 ... 2.95 ft-lb).</li> </ol>

Installation work	
Figure	Description / explanation
	<p><b>Recommendation:</b></p> <ol style="list-style-type: none"> <li>In order to make it easier to service the product, install a shut-off valve [X6] in the condensate inlet line [X5].</li> <li>For the condensate inlet line [X5], apply a sealant to the end of a pressure-resistant pipe and screw this end into the condensate inlet [C].</li> </ol>
	<ol style="list-style-type: none"> <li>For the condensate outlet, push the provided hose [X7] onto the barbed hose fitting [8] and fasten it with a hose clamp.</li> <li>Connect the other end of the hose [X7] to the condensate outlet line [X8].</li> </ol>
Concluding work	
1.	Before pressurization, check all system connections for leak tightness and tighten if necessary.



## 7. Electrical installation

### 7.1 Warning notices

<b>Personnel</b>	
Trained electricians (refer to section “2.3 Target group and personnel” on page 8)	
<b>DANGER</b>	<b>Electrical voltage</b>
	<p>Contact with live components may result in serious injury or death.</p> <ul style="list-style-type: none"> <li>• Always de-energize and isolate the product and accessories and lock and tag them out before starting any installation, maintenance, or repair work on them.</li> <li>• Comply with all locally applicable legal requirements and regulations during installation.</li> <li>• Connect the equipment grounding conductor (grounding) in compliance with all applicable standards and regulations.</li> </ul>
<b>WARNING</b>	<b>Ingress of moisture or foreign objects</b>
	<p>Removing components or opening the product can result in water or foreign objects entering the opened product. This can result in accidents, personal injury, and property damage, as well as problems during operation.</p> <ul style="list-style-type: none"> <li>• Protect the product from splash water and moisture.</li> <li>• Only open the product or remove components in a dry place.</li> <li>• Do not introduce any foreign objects into the product’s openings.</li> <li>• Keep all contact surfaces and openings free of impurities and moisture.</li> </ul>

### 7.2 Connection work

Before the following connection work is carried out, the prerequisites below must be met and all preparation work must have been completed.

<b>Prerequisites</b>		
<b>Tools</b>	<b>Material</b>	<b>Protective equipment</b>
<ul style="list-style-type: none"> <li>• Stripping tool</li> <li>• Crimping pliers for connecting lines</li> <li>• Slotted screwdriver Drive size: 2.5 mm (0.09 in)</li> <li>• Torx screwdriver - T15</li> </ul>	<ul style="list-style-type: none"> <li>• 2-wire cable for 230 V power supply</li> <li>• 2-wire cable for 24 V power supply</li> </ul>	<p style="text-align: center;"><b>To be worn at all times:</b></p> <div style="display: flex; justify-content: center; gap: 20px;">   </div>
<b>Preparatory work</b>		
1.	Installation has been completed (refer to section “6. Installation” on page 24).	

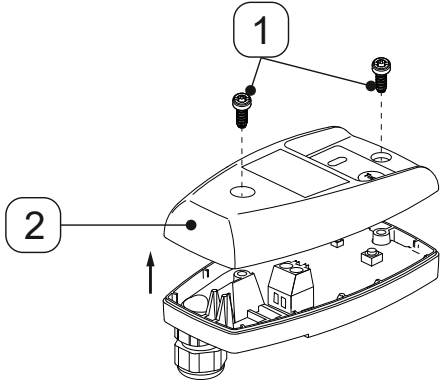
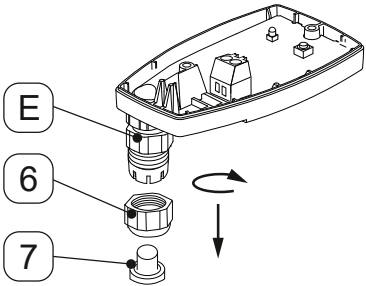
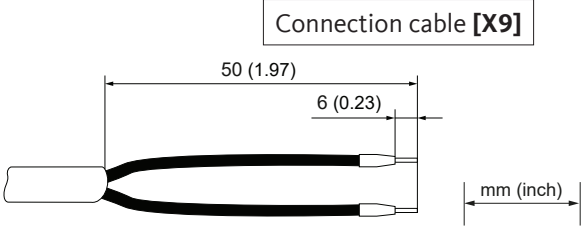
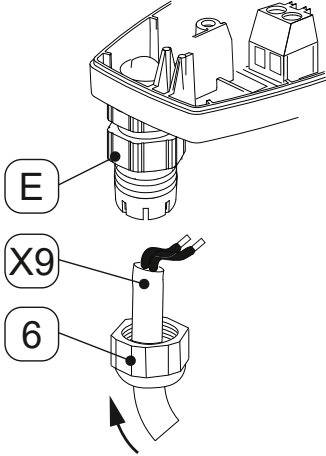

### 7.2.1 Connecting the power supply

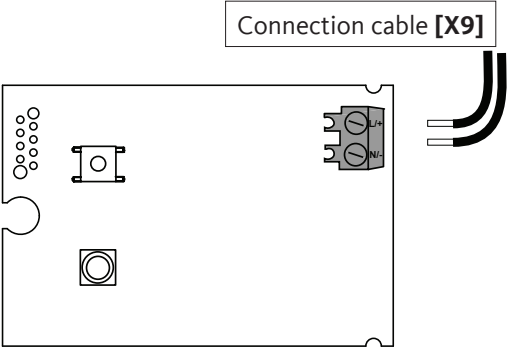
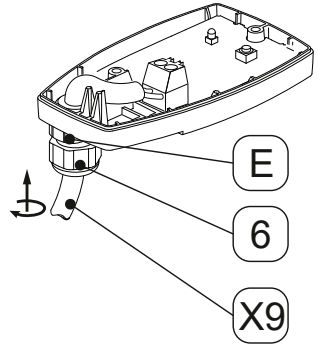
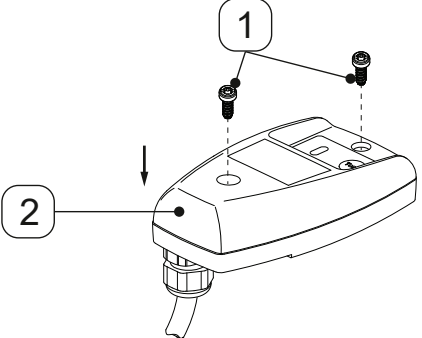
Connection work	
Figure	Description / explanation
	<ol style="list-style-type: none"> <li>1. Remove the two screws <b>[1]</b>.</li> <li>2. Lift the top cover <b>[2]</b>.</li> </ol>
	<ol style="list-style-type: none"> <li>3. Unscrew the locknut <b>[6]</b> from the cable fitting <b>[E]</b>.</li> <li>4. Remove the plug <b>[7]</b> from the locknut <b>[6]</b>.</li> </ol>
 <p style="text-align: center;">Connection cable <b>[X9]</b></p> <p style="text-align: center;">50 (1.97)</p> <p style="text-align: center;">6 (0.23)</p> <p style="text-align: right;">mm (inch)</p>	<ol style="list-style-type: none"> <li>5. Prepare the connection cable <b>[X9]</b>.</li> </ol>
	<ol style="list-style-type: none"> <li>6. Slide the locknut <b>[6]</b> over the connection cable <b>[X9]</b>.</li> <li>7. Insert the connection cable <b>[X9]</b> into the cable fitting <b>[E]</b>.</li> </ol>

Connection work	
Figure	Description / explanation
 <p style="text-align: center;">Connection cable [X9]</p>	<p>8. Connect the connection cable [X9] as shown in the terminal diagram (refer to “4.7 Terminal diagram” on page 22).</p>
	<p>9. Tighten the connection cable [X9].</p> <p>10. Screw the locknut [6] onto the cable fitting [E].</p>
	<p>11. Put the top cover [2] in place and insert the screws [1].</p> <p>12. Tighten the screws [1] with a torque of 0.9 Nm +0.5 Nm (0.66 ft-lb +0.37 ft-lb).</p>

## 8. Commissioning

### 8.1 Warning notices

<b>Personnel</b>	
Skilled technical personnel specializing in pressure equipment and systems and trained electricians (refer to section "2.3 Target group and personnel" on page 8)	
<b>DANGER</b>	<b>Sudden escape of pressurized fluids</b>
	<p>There is a danger of death or serious personal injury resulting from contact with fast or suddenly escaping fluids or through bursting system parts.</p> <ul style="list-style-type: none"> <li>• Before pressurization, check all system connections for leak tightness and tighten if necessary.</li> <li>• Slowly pressurize the system.</li> </ul>
<b>DANGER</b>	<b>Electrical voltage</b>
	<p>Contact with live components may result in serious injury or death, as well as malfunctions and/or property damage.</p> <ul style="list-style-type: none"> <li>• Only operate the product and accessories with a complete and closed cover, closed electronic housing, or closed control cabinet.</li> <li>• Check the product and accessories in compliance with all locally applicable legal requirements and regulations before placing them into operation.</li> </ul>

### 8.2 Commissioning work

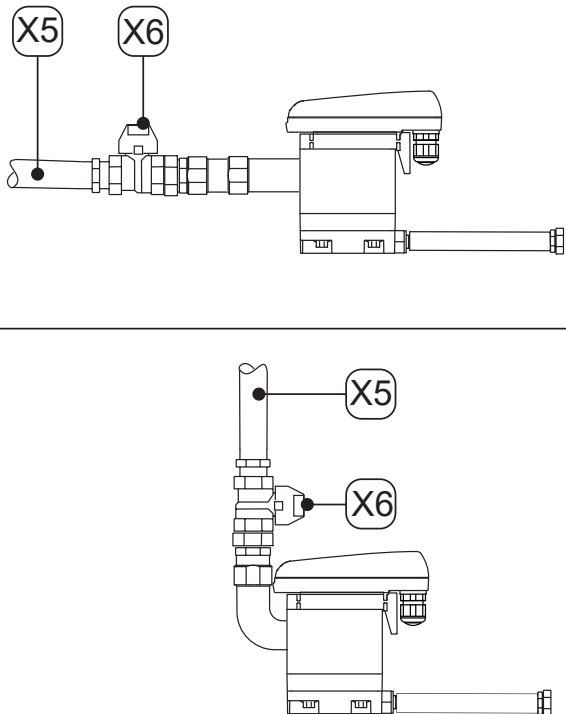
Figure	Description / explanation
 <p>The figure consists of two line drawings of the ZL Drain 31 BI unit. The top drawing shows the unit from a side perspective with a horizontal condensate inlet line on the left. A dot on this line is labeled 'X5', and a shut-off valve on the line is labeled 'X6'. The bottom drawing shows the unit from a front perspective, with the condensate inlet line extending upwards. A dot on this line is labeled 'X5', and the shut-off valve is labeled 'X6'.</p>	<ol style="list-style-type: none"> <li>1. Power the device.</li> <li>2. Slowly pressurize the system section (e.g., slowly open the recommended shut-off valve <b>[X6]</b> in the condensate inlet line <b>[X5]</b>).</li> <li>3. Perform a function test (refer to "10.3.2 Function test" on page 38).</li> </ol>

## 9. Operation

### 9.1 Warning notices

Personnel	
Operating personnel (see section “2.3 Target group and personnel” on page 8)	
<b>DANGER</b>	<b>Electrical voltage</b>
	<p>Contact with live components may result in serious injury or death.</p> <ul style="list-style-type: none"> <li>Only operate the product and accessories with a complete and closed cover, closed electronic housing, or closed control cabinet.</li> </ul>

### 9.2 Operating conditions

Figure	Description / explanation
	<p><b>Not powered</b></p> <ul style="list-style-type: none"> <li>LED off</li> </ul>
	<p><b>Switching on / power-on self-test</b></p> <ul style="list-style-type: none"> <li>All LEDs are on for 1 second.</li> <li>The <b>ZL Drain</b> will run a diagnostic routine on its electronics</li> </ul>
	<p><b>Positive power-on self-test</b>  <b>Number of repetitions n = 2x</b></p> <ul style="list-style-type: none"> <li>The green POWER LED will be on (100% brightness) while the solenoid valve is being actuated</li> <li>The green POWER LED will be on (50% brightness) while the solenoid valve is not being actuated                      → The <b>ZL Drain</b> will switch to normal operation</li> </ul>





Figure	Description / explanation
	<p><b>Negative power-on self-test</b>  <b>Number of repetitions n = 20x</b></p> <ul style="list-style-type: none"> <li>• The green POWER LED will be on (100% brightness) while the solenoid valve is being actuated quickly</li> <li>• The green POWER LED will be on (50% brightness) while the solenoid valve is not being actuated                      → The <b>ZL Drain</b> will switch to fail-safe operation (endless loop = ∞)</li> <li>• The solenoid valve will be actuated once per second</li> </ul>
	<p><b>Ready for operation (normal operation)</b></p> <ul style="list-style-type: none"> <li>• The green power LED is on</li> </ul>
	<p><b>Drain mode</b></p> <ul style="list-style-type: none"> <li>• The green power LED is on</li> </ul>
	<p><b>Maintenance message</b></p> <ul style="list-style-type: none"> <li>• The green POWER LED will flash.                      → Replace the Service-Unit.</li> </ul>

For more information on error messages during operation, refer to section “15. Troubleshooting” on page 46.

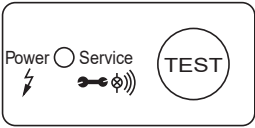
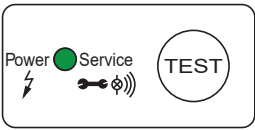
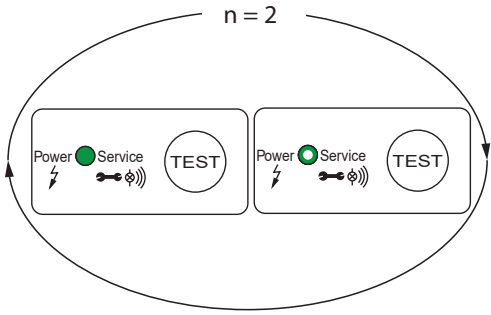
# 10. Maintenance

## 10.1 Warning notices

<b>Personnel</b>	
Qualified service technicians (see section “2.3 Target group and personnel” on page 8)	
<b>DANGER</b>	<b>Sudden escape of pressurized fluids</b>
	<p>There is a danger of death or serious personal injury resulting from contact with fast or suddenly escaping fluids or through bursting system parts.</p> <ul style="list-style-type: none"> <li>• Before starting work, depressurize the pressurized system and secure it against unintentional pressurization.</li> </ul>
<b>DANGER</b>	<b>Electrical voltage</b>
	<p>Contact with live components may result in serious injury or death.</p> <ul style="list-style-type: none"> <li>• Do not carry out maintenance or repair work on the product unless it has first been de-energized and locked and tagged out.</li> <li>• Comply with all locally applicable legal requirements and regulations during installation.</li> </ul>
<b>WARNING</b>	<b>Ingress of moisture or foreign objects</b>
	<p>Removing components or opening the product can result in water or foreign objects entering the opened product. This can result in accidents, personal injury, and property damage, as well as problems during operation.</p> <ul style="list-style-type: none"> <li>• Protect the product from splash water and moisture.</li> <li>• Only open the product or remove components in a dry place.</li> <li>• Do not introduce any foreign objects into the product’s openings.</li> <li>• Keep all contact surfaces and openings free of impurities and moisture.</li> <li>• Do not clean the product with a pressure washer or steam cleaner.</li> </ul>

## 10.2 Maintenance schedule

Maintenance	Interval
Service-Unit replacement	After 2 x 8760 operating hours or one (1) million switching cycles*, but no later than every two years
Cleaning	Annually
Function test	Monthly
Visual inspection	Weekly
Leak test	After installation work, maintenance work, and servicing work on the product

\* based on 7 bar(g) (101.5 psi(g)) and pH-neutral condensate

<b>INFORMATION</b>	<b>When to carry out cleaning work</b>
	Carry out the cleaning work while replacing wear parts, as all parts will be disassembled at this point.

### 10.3 Maintenance work

For maintenance work to be carried out, the following prerequisites must be fulfilled and the preparatory tasks must have been completed.

Prerequisites		
Tools	Material	Protective equipment
<ul style="list-style-type: none"> <li>Slotted screwdriver Drive size: 2.5 mm (0.09 in)</li> <li>Open-end wrench or adjustable wrench</li> </ul>	<ul style="list-style-type: none"> <li>Sealants</li> <li>Lubricant for greasing the O-rings</li> <li>Mild cleaning agent</li> <li>Cotton cloth or disposable cloth</li> </ul>	<p><b>To be worn at all times:</b></p> 

Preparatory work	
1.	Removal from service must be complete (refer to "12. Removal from service" on page 41).

#### 10.3.1 Service-Unit replacement

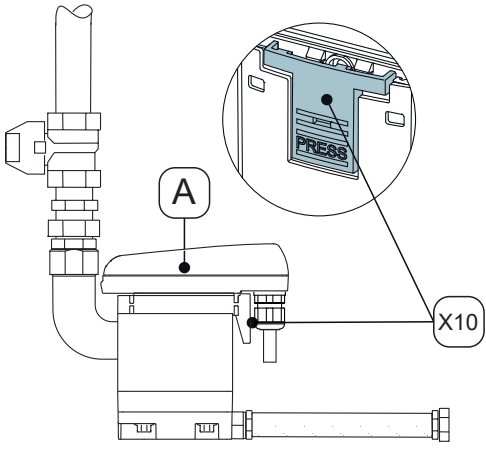
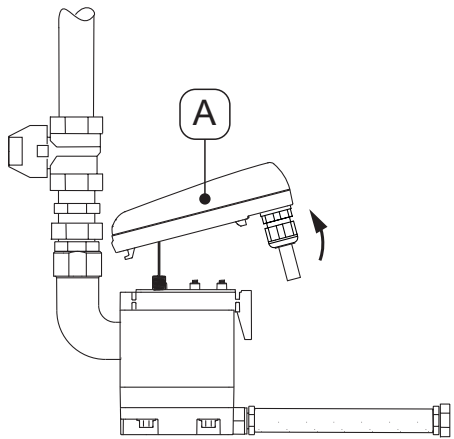
Replacement work	
Figure	Description / explanation
	<p>1. Release the control unit [A] by pressing on the latching tab [X10].</p>
	<p>2. Remove the control unit [A].</p>

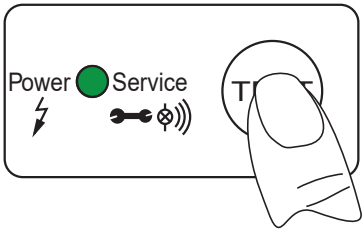
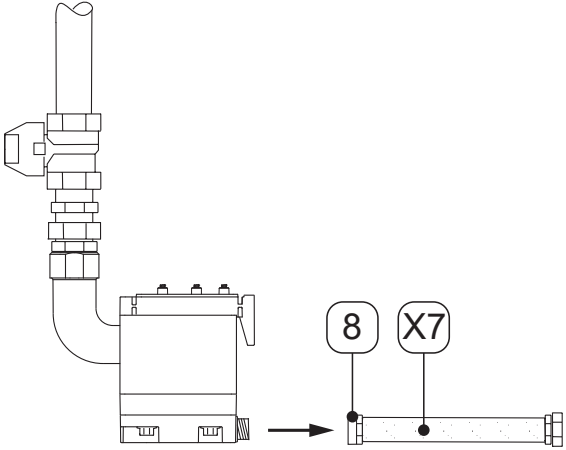
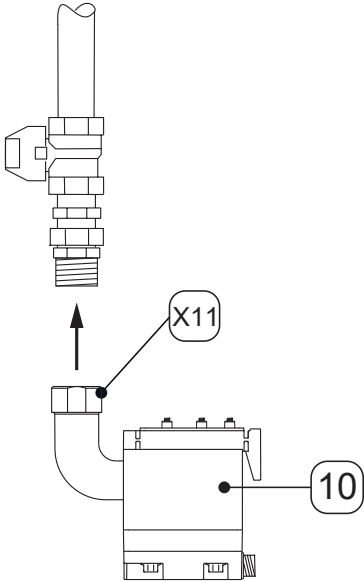
Replacement work	
Figure	Description / explanation
 <p>The diagram shows a control unit with two LEDs: a green 'Power' LED and a red 'Service' LED. A hand is shown pressing a button labeled 'TEST'.</p>	<ol style="list-style-type: none"> <li>3. Press the TEST button on the control unit <b>[A]</b> and hold it down for at least five seconds. → The green POWER LED will flash</li> <li>4. Stop pressing the TEST button as soon as the green POWER LED shows a solid light. → The “service time” counter has now been reset</li> <li>5. Carefully set the control unit aside <b>[A]</b>.</li> </ol>
 <p>The diagram shows a side view of the control unit with a barbed hose fitting labeled '8' and a hose labeled 'X7' attached to it. An arrow points to the fitting.</p>	<ol style="list-style-type: none"> <li>6. Unscrew the barbed hose fitting <b>[8]</b> with the hose <b>[X7]</b>.</li> </ol>
 <p>The diagram shows the control unit with a Service-Unit labeled '10' attached to its side. A union nut labeled 'X11' is shown being loosened to separate the Service-Unit from the pipe.</p>	<ol style="list-style-type: none"> <li>7. Remove the Service-Unit <b>[10]</b> from the pipe on the condensate inlet by loosening the union nut <b>[X11]</b>.</li> <li>8. Dispose of the old Service-Unit properly (refer to “14. Disposal” on page 45).</li> </ol>

Replacement work	
Figure	Description / explanation
	<p>9. Check whether the new Service-Unit <b>[10]</b> is compatible with the control unit <b>[A]</b>:</p> <ul style="list-style-type: none"> <li>→ Model</li> <li>→ The color of the latching tab <b>[X10]</b> is exactly the same as the color of the control unit</li> </ul> <p>10. Pipe the new Service-Unit <b>[10]</b> to the condensate inlet.</p> <p>11. Tighten the union nut <b>[X11]</b>.</p>
	<p>12. Install the barbed hose fitting <b>[8]</b> with the hose <b>[X7]</b>.</p>
	<p>13. Check to make sure that the sealing mat <b>[13]</b> and the contact springs <b>[X12]</b> are clean, dry, and free of foreign objects.</p> <p>14. Insert the control unit <b>[A]</b> sensor into the sensor tube opening.</p>

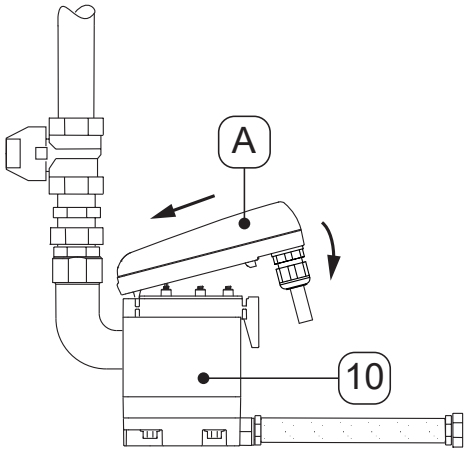
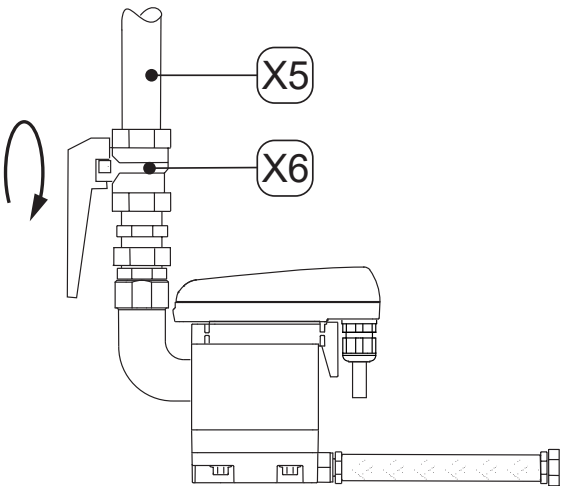
Replacement work	
Figure	Description / explanation
	<p>15. Insert the control unit <b>[A]</b> tab in place.</p> <p>16. Push the control unit <b>[A]</b> against the Service-Unit <b>[10]</b> and latch it into place.</p>
	<p>17. Test all fittings for leaks.</p> <p>18. Carefully start the flow of condensate through the condensate inlet lines <b>[X5]</b> (e.g., open the recommended shut-off valve <b>[X6]</b>).</p>

### 10.3.2 Function test

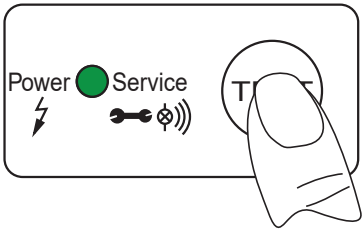
Figure	Description / explanation
	<p>Press the TEST button for 2 ... 5 seconds.</p> <ul style="list-style-type: none"> <li>→ The green POWER LED is on</li> <li>→ The valve opens and condensate is drained.</li> </ul>

### 10.3.3 Visual inspection



During the visual inspection of the product, check all components for mechanical damage and corrosion. Replace damaged components immediately.

### 10.3.4 Leak test

Leak testing is a non-destructive type of test that is used to verify the leak tightness of vacuum and overpressure systems. There are multiple leak test methods available. The manufacturer does not recommend any specific method over another. The company operating the pressurized system is responsible for selecting and specifying the test method. The corresponding test must be carried out in conformity with all applicable standards and guidelines (e.g., DIN EN 1779).

### 10.3.5 Cleaning

## 10.4 Warning notices

<b>CAUTION</b>	<b>Personal injury caused by the incorrect use of cleaning agents</b>
	<p>Improper use of cleaning agents may result in minor injuries and damage to health.</p> <ul style="list-style-type: none"> <li>• Never clean the device with a cloth that is dripping wet.</li> <li>• Do not clean the product with a pressure washer.</li> <li>• Never use abrasive or aggressive cleaning agent or solvents which could damage the outer coating (e.g. markings, type plate, corrosion protection, etc.).</li> <li>• Never clean the device with hard or pointed implements.</li> <li>• Use an anti-static, damp cloth for cleaning the outside.</li> <li>• Immediately replace any product markings (pictograms, markings) that have become illegible.</li> <li>• Use personal protective equipment.</li> <li>• Use cleaning agents in accordance with the manufacturer's instructions.</li> </ul>
<b>NOTICE</b>	<b>Observe all local hygiene regulations</b>
	In addition to the cleaning instructions listed, any regionally applicable or company-specific hygiene regulations must be observed.

#### Preparatory work

1.	Removal from service must be complete (refer to section "12. Removal from service" on page 41).
----	---

#### Cleaning work

1.	Spray mild cleaning agent onto a cotton cloth or disposable wipe until it is damp (not wet).
2.	Wipe the surfaces of the product with the damp cloth.

#### Concluding work

1.	Put the product into operation (see section "8. Commissioning" on page 31).
----	---

# 11. Consumables, accessories, and spare parts

## 11.1 Order information

The manufacturer's service team will need the following information when handling inquiries or orders:

- Serial number (see type plate)
- Part number and name of the accessory or spare part
- Desired quantity of accessories or spare parts

The contact information for the manufacturer's service team is listed in section "1.1 Contact" on page 5.

## 11.2 Accessories

Description	Part No.
Pipe trace heating 230 VAC	on demand
Drain kit	on demand



## 11.3 Spare parts

Description / explanation	Part No.
<b>ZL Drain 31 S-unit</b>	on demand
Set of seals	on demand



## 12. Removal from service

### 12.1 Warning notices

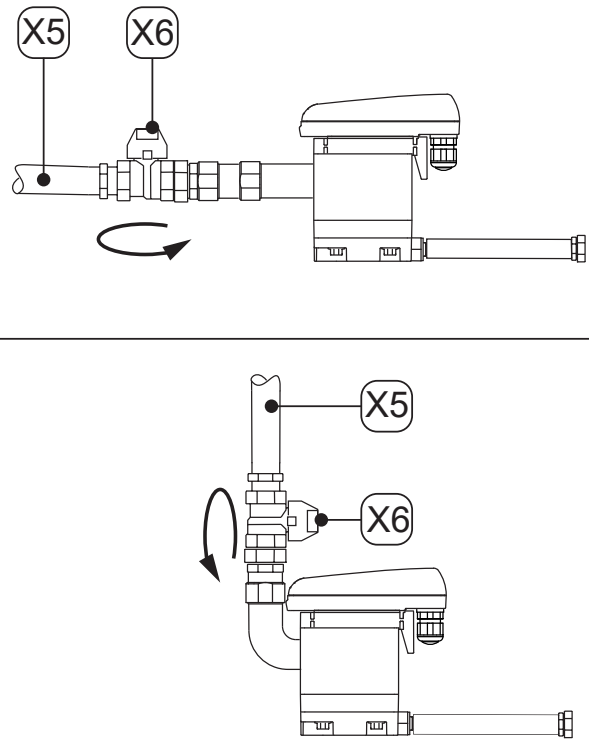
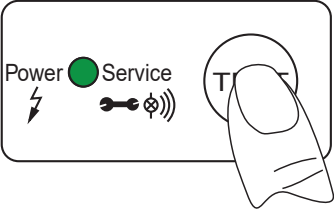

<b>Personnel</b>	
Qualified service technicians (see section "2.3 Target group and personnel" on page 8)	
<b>DANGER</b>	<b>Sudden escape of pressurized fluids</b>
	<p>There is a danger of death or serious personal injury resulting from contact with fast or suddenly escaping fluids or through bursting system parts.</p> <ul style="list-style-type: none"> <li>• Set up a safe area around the work area before starting work.</li> <li>• Before starting work, depressurize the pressurized system and secure it against unintentional pressurization.</li> </ul>
<b>DANGER</b>	<b>Electrical voltage</b>
	<p>Contact with live components may result in serious injury or death, as well as malfunctions and/or property damage.</p> <ul style="list-style-type: none"> <li>• Set up a safe area around the work area before starting work.</li> <li>• Before starting work, de-energize the product and the accessories and lock and tag them out.</li> </ul>

## 12.2 Removal from service

Figure	Description / explanation
	<ol style="list-style-type: none"> <li>1. Stop the flow of condensate through the condensate inlet lines <b>[X5]</b> (e.g., close the recommended shut-off valve <b>[X6]</b>).</li> </ol>
	<ol style="list-style-type: none"> <li>2. Briefly press the TEST button several times. <ul style="list-style-type: none"> <li>→ The pressure in the <b>ZL Drain</b> will be reduced.</li> <li>→ The remaining condensate in the <b>ZL Drain</b> is drained off.</li> </ul> </li> <li>3. Disconnect the <b>ZL Drain</b> from the power supply and switch it off.</li> </ol>



## 13. Disassembly

### 13.1 Warning notices

<b>Personnel</b>	
Qualified service technicians (see section "2.3 Target group and personnel" on page 8)	
<b>DANGER</b>	<b>Sudden escape of pressurized fluids</b>
	<p>There is a danger of death or serious personal injury resulting from contact with fast or suddenly escaping fluids or through bursting system parts.</p> <ul style="list-style-type: none"> <li>• Set up a safe area around the work area before starting work.</li> <li>• Before starting work, depressurize the pressurized system and secure it against unintentional pressurization.</li> </ul>
<b>DANGER</b>	<b>Electrical voltage</b>
	<p>Contact with live components may result in serious injury or death, as well as malfunctions and/or property damage.</p> <ul style="list-style-type: none"> <li>• Set up a safe area around the work area before starting work.</li> <li>• Before starting work, de-energize the product and the accessories and lock and tag them out.</li> </ul>

### 13.2 Disassembly work

For disassembly work to be carried out, the following prerequisites must be fulfilled and the preparatory tasks must have been completed.

<b>Prerequisites</b>		
<b>Tools</b>	<b>Material</b>	<b>Protective equipment</b>
<ul style="list-style-type: none"> <li>• Open-end wrench or adjustable wrench</li> </ul>	<ul style="list-style-type: none"> <li>• No material necessary</li> </ul>	<p style="text-align: center;"><b>To be worn at all times:</b></p> <div style="display: flex; justify-content: space-around; align-items: center;">    </div>

<b>Preparatory work</b>	
1.	Removal from service must be complete (refer to section "12. Removal from service" on page 41).
2.	Depressurize the pressurized system or the corresponding system section and secure it against unintentional pressurization.

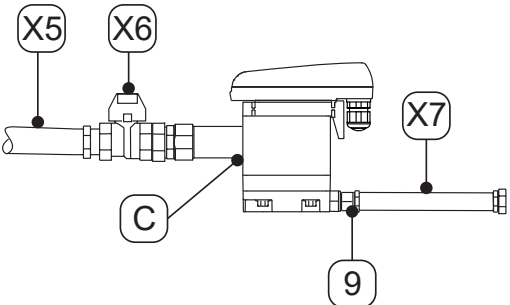
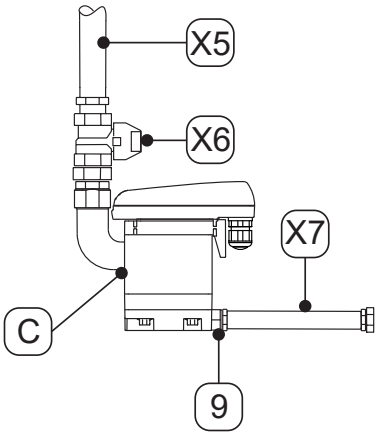
Disassembly work	
Figure	Description / explanation
	<ol style="list-style-type: none"> <li>1. Remove the hose [X7] from the barbed hose fitting [9].</li> </ol>
	<ol style="list-style-type: none"> <li>2. Remove the condensate inlet line [X5] and the recommended shut-off valve [X6] from the condensate inlet [C].</li> <li>3. Disassemble all electrical connections.</li> </ol>

## 14. Disposal

At the end of their useful life the product and the accessories must be sent for disposal e.g. by a specialist company. Materials such as glass, plastics and some chemical compounds are mostly recoverable, reusable or recyclable.

### 14.1 Warning notices

NOTICE	Improper disposal
	<p>Improper disposal of parts, components, operating and auxiliary materials as well as cleaning media can cause environmental damage.</p> <ul style="list-style-type: none"> <li>• Dispose of all components, parts, operating and auxiliary materials as well as cleaning agents professionally and in accordance with all locally applicable legal requirements and regulations.</li> <li>• Dispose of electrical and electronic components through a specialized disposal company or return them to the manufacturer.</li> <li>• In case of doubt, consult a local disposal company before disposal.</li> </ul>

### 14.2 Disposal of operating and auxiliary materials

Disposal work	
1.	Collect and dispose of all operating fluids, auxiliary materials, and cleaning agents in accordance with all locally applicable legal requirements and regulations.

### 14.3 Disposal of components

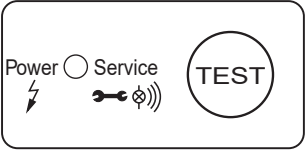
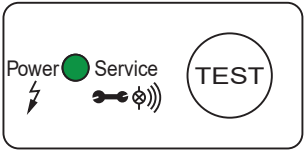
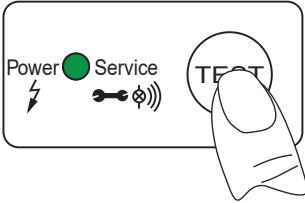
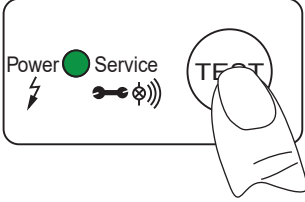
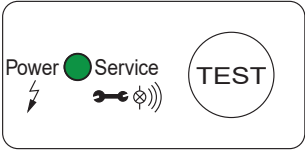

Disposal work	
1.	Remove the product and accessories from service and disassemble them (refer to section “13. Disassembly” on page 43).
2.	Clean the product and accessories and remove any fluid residues from them (refer to section “10.3.5 Cleaning” on page 39).
3.	Dispose of the product and accessories in accordance with all locally applicable legal requirements and regulations.

# 15. Troubleshooting

Error or fault pattern	Possible causes	Troubleshooting
	<ul style="list-style-type: none"> <li>• None of the LEDs are turning on</li> </ul>	<ul style="list-style-type: none"> <li>• Read and check the operating voltage on the type plate</li> <li>• Check whether the terminals on the sensor board (L, N) are powered</li> <li>• Check the plug connection at the terminal on the sensor board</li> </ul>
	<ul style="list-style-type: none"> <li>• The green power LED is on at all times.</li> </ul>	<ul style="list-style-type: none"> <li>• Disconnect the product from the operating voltage and reconnect it after &gt; 5 seconds.</li> <li>• Check the sensor board for possible damage</li> </ul>
	<ul style="list-style-type: none"> <li>• No condensate is discharged after pressing the TEST button.</li> </ul>	<ul style="list-style-type: none"> <li>• Check the inlet and drain lines.</li> <li>• Check the valve's operation by pressing the TEST button.                             <ul style="list-style-type: none"> <li>→ The switching of the valve is clearly audible (clacking noise).</li> </ul> </li> <li>• Replace the Service-Unit</li> <li>• Check the plug connection at the terminal on the sensor board</li> </ul>
	<ul style="list-style-type: none"> <li>• Condensate is only discharged when the TEST button is pressed.</li> </ul>	<ul style="list-style-type: none"> <li>• Route the inlet line with a downward slope &gt;3%.</li> <li>• Install a vent line</li> <li>• Check if the required minimum pressure is being reached (refer to "4. Technical data" on page 19).</li> <li>• Replace the Service-Unit</li> </ul>
	<ul style="list-style-type: none"> <li>• The <b>ZL Drain</b> keeps discharging condensate without ever stopping.</li> </ul>	<ul style="list-style-type: none"> <li>• Replace the Service-Unit</li> </ul>

## 16. Appendices

### 16.1 Certificates

Symbol	Description / explanation
	<p><b>FCC mark</b></p> <p>The FCC mark indicates that a product conforms to the requirements of the Federal Communications Commission (FCC) and confirms that basic health and safety requirements have been met during the manufacture of the product. The product may be sold on the US market.</p>
	<p><b>cTÜVus marking</b></p> <p>The cTÜVus marking indicates that a product meets the requirements of TÜV Rheinland for the Canadian and US markets and confirms that basic health and safety requirements have been met during the manufacture of the product. The product may be sold on the Canadian and US markets.</p>
	<p><b>WEEE label</b></p> <p>The crossed-out waste bin indicates an electrical or electronic product that must not be disposed of in household waste at the end of its service life. Free collection points for old electrical and electronic products are available for returning the product, as well as other collection points for reusing the product, if necessary. Addresses can be obtained from the local government.</p>



**SULLIVAN**  
**PALATEK**  
AIR COMPRESSORS

1201 West US Highway 20  
Michigan City, Indiana 46360  
Phone: 219.874.2497  
Fax: 219.809.0203  
info@palatek.com  
www.sullivan-palatek.com