



EN - english

Instructions for installation and operation

Compressed air refrigeration dryer

SPRHT 20T - 350T

Dear customer,

Thank you for deciding in favour of the SPRHT 20T – 350T compressed-air refrigeration dryer. Please read these installation and operating instructions carefully before mounting and starting up the SPRHT 20T – 350T and follow our directions. Perfect functioning of the SPRHT 20T – 350T and thus reliable compressed-air drying can only be guaranteed when the provisions and notes stipulated here are strictly adhered to.

Contents

1	Name plate	5
2	Safety instructions	5
2.1	Safety pictograms in accordance with DIN 4844	6
2.2	Signal words in accordance with ANSI	7
2.3	Overview of the safety instructions	7
3	Proper use	9
4	Exclusion from a field of application	9
5	Instructions for the use of pressure equipment according to PED directive 2014/68/EU	10
6	Transport	11
7	Storage	11
8	Installation	11
8.1	Place of installation	11
8.2	Installation plan	12
8.3	Correction factors	13
8.4	Connection to the compressed-air system	14
8.5	Electrical connections	14
8.7	Condensate drain	15
9	Start-up	16
9.1	Preliminary stages	16
9.2	Initial start-up	16
9.3	Start-up and shut down	17
10	Technical data	18
10.1	Technical data SPRHT 20-T150T 1/115/60	18
10.2	Technical data SPRHT 150T-350T 1/230/60	19
11	Technical description	20
11.1	Control panel	20
11.2	Functional description	20
11.3	Flow chart	21
11.4	Refrigerating compressor	22
11.5	Condenser	22
11.6	Aftercooler	22
11.7	Pre-Filter (1 micron)	22
11.8	Filter dryer	22
11.9	Capillary tube	22
11.10	Aluminium heat exchanger	22
11.11	Hot-gas bypass valve	22
11.12	Refrigerant pressure switches LPS – HPS	23
11.13	Safety temperature switch TS	23
11.14	Aftercooler safety thermo-switch TSA	23
11.15	Electronic controller DMC34	24
11.15.1	How to switch on the dryer	24
11.15.2	How to switch off the dryer	24
11.15.3	How to display the operating parameters	24
11.15.4	How a service warning / alarm is displayed	24
11.15.5	How is controlled the condenser fan	25
11.15.6	How is controlled the drain solenoid valve	25
11.15.7	How to reset the service reminder timer	25
11.15.8	Operation of the failure / alarm dry contact	25
11.15.9	How to change the operating parameters	26
11.16	Electronic level controlled ZL Drain	26
12	Maintenance, troubleshooting, spare parts and dismantling	27
12.1	Checks and maintenance	27
12.3	Troubleshooting	29
12.4	Recommended spare parts	32
12.5	Maintenance works at the refrigeration cycle	33
12.6	Dismantling the dryer	33

13	Appendices	34
13.1	Dryer dimensions	34
13.1.1	Dryer dimensions SPRHT 20T-50T	34
13.1.2	Dryers Dimensions SPRHT 75T	35
13.1.3	Dryer dimensions SPRHT 100T	36
13.1.4	Dryer dimensions SPRHT 150T	37
13.1.5	Dryers Dimensions SPRHT 200T-250T	38
13.1.6	Dryers Dimensions SPRHT 300T-350T	39
13.2	Exploded diagrams	40
13.2.1	Components of the exploded diagrams	40
13.2.2	Exploded diagram SPRHT 20T-50T	41
13.2.3	Exploded diagram SPRHT 75T	42
13.2.4	Exploded diagram SPRHT 100T	43
13.2.5	Exploded diagram SPRHT 150T-200T	44
13.2.6	Exploded diagram SPRHT 250T-300T	45
13.2.7	Exploded diagram SPRHT 350T	46
13.3	Electric diagrams	47
13.3.1	Electric diagrams – list of components	47
13.3.2	Electric diagram SPRHT 20T-50T	48
13.3.3	Electric diagram SPRHT 75T-100T	49
13.3.4	Electric diagram SPRHT 150T	50
13.3.5	Electric diagram SPRHT 200T-250T	51
13.3.6	Electric diagram SPRHT 300T-350T	52

1 Name plate

The name plate is on the back of the dryer and comprises all primary data of the device. Always refer to these when contacting the manufacturer or the sales department.

All guarantee claims will expire in the event that the name plate is modified or removed.

2 Safety instructions



Please check whether or not these instructions correspond to the device type.

Please adhere to all advice given in these operating instructions. They include essential information which must be observed during installation, operation and maintenance. Therefore, it must be ensured that these operating instructions are read by the fitter and the responsible operator / certified skilled personnel prior to installation, start-up and maintenance.

The operating instructions must be accessible at all times at the place of application of the SPRHT 20T – 350T compressed-air refrigeration dryer.

In addition to these operating instructions, local and national regulations need to be observed, where required .

Ensure that operation of the SPRHT 20T – 350T compressed-air refrigeration dryer only takes place within the permissible limit values indicated on the name plate. Any deviation from these limit values involves a risk for persons and for the material, and may result in malfunction or a breakdown.

After installing the device correctly and in accordance with the instructions in this manual, the dryer is ready to operate, further settings are not required. Operation is fully automatic and maintenance is limited to several examinations and cleaning measures which are described in the following chapters.

This manual must be available at all times for future reference and is a constituent part of the dryer.

If you have any queries regarding these installation and operating instructions, please contact Sullivan Palatek.

Safety instructions

2.1 Safety pictograms in accordance with DIN 4844



Observe operating instructions



General danger symbol



Supply voltage



Danger: component or system under pressure



Hot surfaces



Non-breathable air



Do not use water to extinguish the fire



Do not operate with open cover (housing)



Maintenance works or controlling measures must only be carried out by qualified personnel¹



Do not smoke



Note



Connection point compressed-air inlet



Connection point compressed-air outlet



Connection point condensate drain



Works can be carried out by the operator of the plant, provided that they are skilled accordingly¹.

NOTE: Text that contains important specifications to be considered – does not refer to safety precautions.



The device was carefully designed with particular attention paid to environmental protection:

- CFC-free refrigerants
- CFC-free insulation material
- Energy-saving design
- Limited acoustic emissions
- Dryer and packaging comprise reusable materials

This symbol advises the user to observe the environmental aspects and comply with the recommendations connected with this symbol.

¹ Certified skilled personnel are persons who are authorised by the manufacturer, with experience and technical training, who are well-grounded in the respective provisions and laws and capable of carrying out the required works and of identifying and avoiding any risks during the machine transport, installation, operation and maintenance. Qualified and authorised operators are persons who are instructed by the manufacturer regarding the handling of the refrigeration system, with experience and technical training, and who are well-grounded in the respective provisions and laws.

2.2 Signal words in accordance with ANSI

Danger!	Imminent hazard Consequences of non-observance: serious injury or death
Warning!	Potential hazard Consequences of non-observance: possible serious injury or death
Caution!	Imminent hazard Consequences of non-observance: possible injury or property damage
Notice!	Potential hazard Consequences of non-observance: possible injury or property damage
Important!	Additional advice, info, hints Consequences of non-observance: disadvantages during operation and maintenance, no danger

2.3 Overview of the safety instructions



Certified skilled personnel

Installation works must exclusively be carried out by authorised and qualified skilled personnel. Prior to undertaking any measures on the SPRHT 20T – 350T compressed-air refrigeration dryer, the certified skilled personnel shall read up on the device by carefully studying the operating instructions. The operator is responsible for the adherence to these provisions. The respective directives in force apply to the qualification and expertise of the certified skilled personnel.

For safe operation, the device must only be installed and operated in accordance with the indications in the operating instructions. In addition, the national and operational statutory provisions and safety regulations, as well as the accident prevention regulations required for the respective case of application, need to be observed during employment. This applies accordingly when accessories are used.



Danger!

Compressed air!

Risk of serious injury or death through contact with quickly or suddenly escaping compressed air or through bursting and/or unsecured plant components.

Compressed air is a highly dangerous energy source.

Never work on the dryer when the system is under pressure.

Never direct the compressed-air outlet or condensate drain hoses at persons.

The user is responsible for the proper installation of the dryer. Non-observance of the instructions in the "Installation" chapter leads to the expiration of the guarantee. Improper installation may result in dangerous situations for the personnel and/or the device.



Danger!

Supply voltage!

Contact with non-insulated parts carrying supply voltage involves the risk of an electric shock resulting in injuries and death.

Only qualified and skilled personnel are authorised to run electrically-operated devices. Prior to undertaking maintenance measures at the device, the following requirements must be met:

Make sure that the power supply is switched off and that the device is off and marked for maintenance measures. Please also ensure that the power supply cannot be re-established during the works.



Caution!

Refrigerant!

The compressed-air refrigeration dryer uses HFC-containing refrigerants as a coolant.

Please observe the corresponding paragraph entitled "Maintenance works at the refrigeration cycle".



Warning!

Refrigerant leak!

A refrigerant leak involves the danger of serious injury and damage to the environment.



The SPRHT 20T – 350T compressed-air refrigeration dryer contains fluorinated greenhouse gas/refrigerant.



Installation, repair and maintenance works at the refrigeration system must only be carried out by certified skilled personnel (specialists). A certification in accordance with EC regulation 303/2008 must be available.



The requirements of the EC 842/2006 directive must be met under all circumstances.

Please refer to the indications on the name plate as regards the type and amount of refrigerant.



Comply with the following protective measures and rules of conduct:

1. **Storage:** Keep the container tightly closed. Keep it in a cool and dry place. Protect it against heat and direct sunlight. Keep it away from ignition sources.
2. **Handling:** Take measures against electrostatic charging. Ensure good ventilation/suction at the workplace. Check fittings, connections and ducts for tightness. Do not inhale the gas. Avoid contact with the eyes or the skin.
3. Prior to carrying out works on refrigerant-carrying parts, remove the refrigerant to such an extent that safe working is possible.
4. Do not eat, drink or smoke during work. Keep out of the reach of children.
5. **Breathing protection:** ambient-air-independent respirator (at high concentrations).
6. **Eye protection:** sealing goggles.
7. **Hand protection:** protective gloves (e.g. made of leather).
8. **Personal protection:** protective clothing.
9. **Skin protection:** use protective cream.

In addition, the safety data sheet for the refrigerant needs to be observed!



Caution!

Hot surfaces!

During operation, several components can reach surface temperatures of more than 140°F (60°C). There is the risk of burns.

All components concerned are installed inside of the closed housing. The housing must only be opened by certified skilled personnel².



Caution!

Improper use!



The device is intended for the separation of water in compressed air. The dried air cannot be used for breathing-air purposes and is not suitable for the direct contact with food.

This dryer is not suitable for the treatment of contaminated air or of air containing solids.

² Certified skilled personnel are persons who are authorised by the manufacturer, with experience and technical training, who are well-grounded in the respective provisions and laws and capable of carrying out the required works and of identifying and avoiding any risks during the machine transport, installation, operation and maintenance. Qualified and authorised operators are persons who are instructed by the manufacturer regarding the handling of the refrigeration system, with experience and technical training, and who are well-grounded in the respective provisions and laws.

**Note!****Contaminated intake air!**

In the event that the intake air is strongly contaminated (ISO 8573.1 class 3.-3 or poorer quality), we recommend the additional installation of a prefilter (e.g. ProPure), to avoid clogging of the heat exchanger.

**Caution!****Heating-up through fire!**

In the event of a heating-up through fire, the containers and pipes of the refrigerant system can burst.



In this case, please proceed as follows:

Switch off the refrigeration plant.

Switch off the mechanical ventilation of the machinery compartment.

Use ambient-air-independent respirators.

Containers and plants which are filled with refrigerant can burst violently in the event of fire.

The refrigerants themselves are incombustible, but they are degraded to very toxic products at high temperatures.

Remove the container/plant from the fire zone, as there is the risk of bursting!

Cool down containers and bottles via a directed water jet from a safe position.

In the event of fire, please use an approved fire extinguisher. Water is not a suitable agent to extinguish an electrical fire.

This must only be carried out by persons who are trained and informed about the hazards emanating from the product.

**Caution!****Unauthorised intervention!**

Unauthorised interventions may endanger persons and plants and lead to malfunction.

Unauthorised interventions, modification and abuse of the pressure devices are prohibited.

The removal of sealings and leadings at safety devices is prohibited.

Operators of the devices must observe the local and national pressure equipment regulations in the country of installation.

**Note!****Ambient conditions!**

In the event that the dryer is not installed under suitable ambient conditions, the ability of the device to condense refrigerant gas is impaired. This can result in a higher load of the refrigerating compressor, and in a loss of efficiency and performance of the dryer.

This in turn leads to overheated condenser fan motors, to malfunction of electric components and to a breakdown of the dryer. Failures of this type will affect warranty considerations.

Do not install the dryer in an environment in which chemicals with a corrosive effect, explosive gases, toxic gases, evaporation heat, high ambient temperatures or extreme dust and dirt can be found.

3 Proper use

This dryer was designed, manufactured and tested to separate the moisture which normally exists in compressed air. Any other use is considered improper.

The manufacturer shall not be liable for problems occurring as a consequence of improper use. The user alone is responsible for any damage resulting from that.

Furthermore, the correct use includes the compliance with the installation instructions, in particular in respect of:

- The voltage and frequency of the main voltage supply.
- The pressure, temperature and flow rate of the inlet air.
- The ambient temperature.

When delivered, the dryer is tested and fully assembled. The customer only needs to connect the device to the system in accordance with the instructions in the following chapters.

4 Exclusion from a field of application

**Note!****Improper use!**



The device is intended for the separation of water in compressed air. The dried air cannot be used for breathing-air purposes and is not suitable for the direct contact with food.

This dryer is not suitable for the treatment of contaminated air or of air containing solids.

5 Instructions for the use of pressure equipment according to PED directive 2014/68/EU

The SPRHT 20T – 350T compressed-air refrigeration dryer contains pressure equipment in the sense of the 2014/68/EU Pressure Equipment Directive. Therefore, the entire plant needs to be registered with the supervisory authority if required in accordance with the local regulations.

For the examination prior to the start-up and for periodic inspections, the national regulations need to be observed, such as the industrial safety regulation in the Federal Republic of Germany. In countries outside the EU, the respective regulations in force there need to be adhered to.

The proper use of pressure devices is the basic requirement for safe operation. As regards pressure devices, the following points need to be observed:

- The SPRHT 20T – 350T compressed-air refrigeration dryer must only be employed within the pressure and temperature range limits indicated by the manufacturer on the name plate.
- No welding must be carried out on the pressure parts.
- The SPRHT 20T – 350T compressed-air refrigeration dryer must neither be installed in insufficiently ventilated rooms nor near heat sources or inflammable substances.
- To avoid fractures resulting from material fatigue, the refrigeration dryer should not be exposed to vibrations during operation.
- The maximum operating pressure indicated by the manufacturer on the name plate must not be exceeded. It is the installer's responsibility to install the appropriate safety and control devices. Prior to the start-up of the SPRHT 20T – 350T compressed-air refrigeration dryer, the connected pressure generator (compressor etc.) must be set to the max. permissible operating pressure. The integrated safeguard needs to be checked by an approved inspection agency.
- The documents related to the SPRHT 20T – 350T compressed-air refrigeration dryer (manual, operating instructions, manufacturer's declaration etc.) must be kept safe for future reference.
- No objects whatsoever must be installed at or placed on the SPRHT 20T – 350T compressed-air refrigeration dryer and the connecting lines.
- Installation of the plant in frost-free places only.
- Operation of the plant is only permissible with fully closed and intact housing and cover panels. Operation of the plant with damaged housing/cover panels is prohibited.

6 Transport

Check the packaging for visible loss or damage. If no visible damage can be ascertained, place the unit in close proximity to the place of installation and unpack the device.

During this procedure, the dryer must always remain in an upright position. The components may be damaged when the unit is tilted or turned upside down.

Store the device in a dry environment and do not expose it to extreme weather conditions.

Handle with care. Strong shocks can cause irreparable damage.

7 Storage

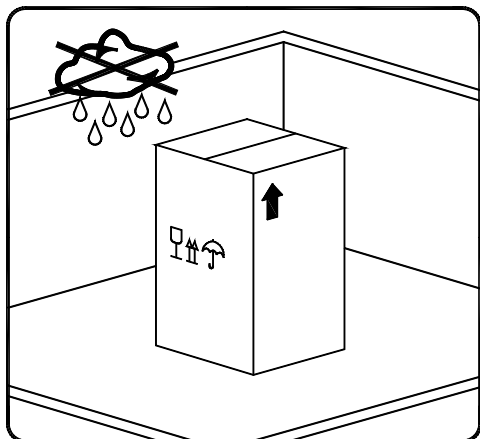

Keep the device away from extreme weather conditions even when packaged.

Keep the dryer in an upright position, also while it is stored. Tilting the device or turning it upside down can cause irreparable damage to some components.

When the dryer is not in use, it can be stored in its packaging in a dust-free and protected place at a temperature of +34°F (+1°C) ... +122°F (+50°C) and at a specific humidity of max. 90%. If the storage period exceeds 12 months, you should contact the manufacturer.



The packaging material is recyclable. Dispose of the material in accordance with the directives and provisions in force in the country of destination

8 Installation

8.1 Place of installation



Note!

Ambient conditions!

In the event that the dryer is not installed under suitable ambient conditions, the ability of the device to condense refrigerant gas is impaired. This can result in a higher load of the refrigerating compressor, and in a loss of efficiency and performance of the dryer.

This in turn leads to overheated condenser fan motors, to malfunction of electric components and to a breakdown of the dryer. Failures of this type will affect warranty considerations.

Do not install the dryer in an environment in which chemicals with a corrosive effect, explosive gases, toxic gases, evaporation heat, high ambient temperatures or extreme dust and dirt can be found.



In case of **fire**, use an approved fire extinguisher, **water** is not an acceptable means in cases of fire.

Minimum installation requirements:

- Select a clean dry area, free from dust, and protected from atmospheric disturbances.
- The supporting area must be smooth, horizontal and able to hold the weight of the dryer.
- Minimum ambient temperature +34 °F (+1 °C).
- Maximum ambient temperature +120°F (50°C).
- Allow at least a clearance of 40 in (1m) on each side of the dryer for proper ventilation and to facilitate eventual maintenance operations.

The dryer does not require attachment to the floor surface; however installations where the unit is suspended require an attachment to the hanging apparatus.

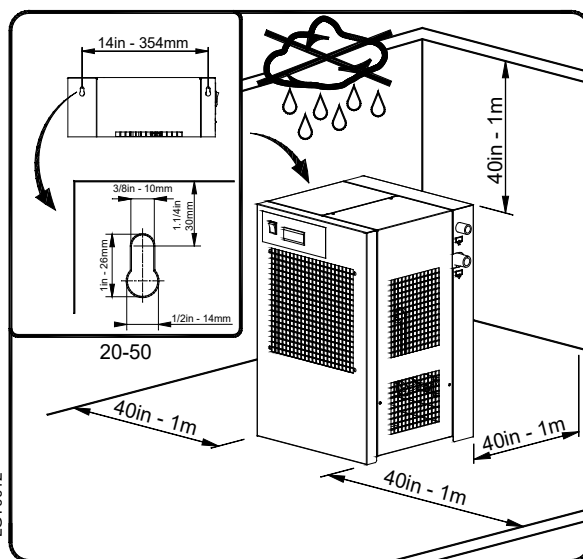

Do not obstruct the ventilation grille (not even partially).

Prevent any recirculation of the outgoing cooling air.
Protect the dryer against draughts.

8.2 Installation plan

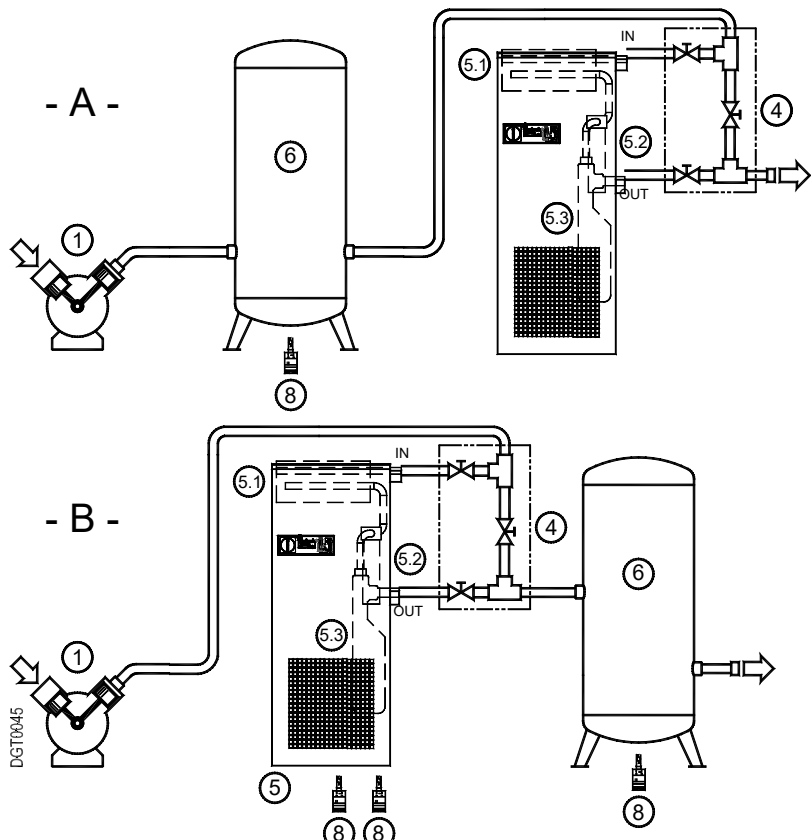

Installation **type A** is recommended when the total consumption corresponds to the throughput rate of the compressor. Installation **type B** is recommended when the air consumption constantly varies, with peak values which considerably exceed the throughput rate of the compressor. The storage capacity of the tank must be dimensioned in such a way that a possible short-term high air demand (peak air consumption) can be compensated.



Do not obstruct the ventilation grille (not even partially).

Prevent any recirculation of the outgoing cooling air.

Protect the dryer against draughts.



Note!

Contaminated intake air!

In the event that the intake air is strongly contaminated (ISO 8573.1 class 3.-3 or poorer quality), we recommend the additional installation of a prefilter (e.g. ProPure), to avoid clogging of the heat exchanger.

8.3 Correction factors

Correction factor for operating pressure modifications:											
Inlet air pressure	psig	60	80	100	120	140	160	180	200	220	230
	barg	4	5.5	7	8	10	11	12.5	14	15	16
Factor (F1)		0.79	0.91	1.00	1.07	1.13	1.18	1.23	1.27	1.31	1.33

Correction factor for ambient temperature modifications:								
Ambient temperature	°F	≤ 80	90	100	105	110	115	120
	°C	≤ 27	32	38	40	43	46	50
Factor (F2)		1.22	1.11	1.00	0.94	0.89	0.83	0.78

Correction factor for inlet air temperature modifications:							
Air temperature	°F	≤ 140	160	170	180	195	210
	°C	≤ 60	70	76	82	90	100
Factor (F3)		1.26	1.13	1.07	1.00	0.90	0.81

Correction factor for DewPoint modifications:					
DewPoint	°F	37	41	45	50
	°C	3	5	7	10
Factor (F4)		0.78	0.90	1.00	1.12

Calculation of the actual air throughput:

Actual air throughput = air throughput acc. to planning x factor (F1) x factor (F2) x factor (F3) x factor (F4)

Example:

An **SPRHT 150T** has a nominal duty of **150 scfm (255 m³/h)**. The highest achievable air mass under the following operating conditions is:

- Air inlet pressure = 120 psig (8 barg) ⇒ ⇒ Factor (F1) = 1.07
- Ambient temperature = 105°F (40°C) ⇒ ⇒ Factor (F2) = 0.94
- Air inlet temperature = 195°F (90°C) ⇒ ⇒ Factor (F3) = 0.90
- Pressure dew point = 45°F (7°C) ⇒ ⇒ Factor (F4) = 1.00

Every function parameter corresponds to a numerical factor which, multiplied by the planned nominal capacity, determines the following:

Air flow capacity = 150 x 1.07 x 0.94 x 0.90 x 1.00 = 137 scfm. (233 m³/h)

137 scfm (233 m³/h) This is the maximum flow rate that the dryer can accept under these operating conditions.

How to select a suitable dryer for a given duty:

Minimum std. air flow rate =	Design air flow
	Factor (F1) x Factor (F2) x Factor (F3) x Factor (F4)

Example:

The following operating parameters are known:

- Required air mass = 95 scfm (161 m³/h) ⇒
- Air inlet pressure = 120 psig (8 barg) ⇒ ⇒ Factor (F1) = 1.07
- Ambient temperature = 105°F (40°C) ⇒ ⇒ Factor (F2) = 0.94
- Air inlet temperature = 195°F (90°C) ⇒ ⇒ Factor (F3) = 0.90
- Pressure dew point = 45°F (7°C) ⇒ ⇒ Factor (F4) = 1.00

In order to select the correct dryer model the required flow rate is to be divided by the correction factors relating to above mentioned parameters:

Minimum std. air flow rate =	95		= 104 scfm (177 m³/h)
	1.07 x 0.94 x 0.90 x 1.0		

Therefore the model suitable for the conditions above is **SPRHT 150T (150 scfm or 255 m³/h - nominal duty)**.

8.4 Connection to the compressed-air system



Danger! **Compressed air!**

All works must only be carried out by qualified skilled personnel.



Never work on compressed-air systems which are under pressure.

The operator or the user must ensure that the dryer is never operated with a pressure exceeding the maximum pressure value indicated on the name plate.

Exceeding the maximum operating pressure can be dangerous for the operator but also for the device.

The air temperature and the air flow at the inlet of the dryer must lie within the limit values indicated on the name plate. The connecting lines must be free from dust, iron rust, shards and other contaminations and correspond to the flow rate of the dryer. Should air with a very high temperature be treated, the installation of an aftercooler may be necessary. For the implementation of maintenance works, the installation of a bypass system is recommended.

The dryer was designed in such a manner that vibrations that may occur during operation are limited. Therefore, it is advisable to employ connecting lines (flexible hoses, vibration-inhibiting fittings etc.) which protect the dryer against possible vibrations in the pipework.

Note!



Contaminated intake air!

In the event that the intake air is strongly contaminated (ISO 8573.1 class 3.-3) or poorer quality, we recommend the additional installation of a prefilter (e.g. ProPure), to avoid clogging of the heat exchanger.

8.5 Electrical connections



Danger! **Supply voltage!**

The connection to the electric mains should only be carried out by qualified skilled personnel and must correspond to the legal provisions in force in your region.

Prior to connecting the device, please check the name plate to avoid exceeding the indicated values. The voltage tolerance is +/- 10%.

SPRHT 20T – 350T dryers are supplied with a power cord and safety plug (two-pole and earth connection).

Make sure that suitable fuses or circuit breakers in accordance with the indications on the name plate are available.

A residual-current device (RCD) with $I_{\Delta n} = 0.03A$ is suggested. The cross-section of the power supply cable must correspond to the power consumption of the dryer. In this respect, the ambient temperature, the cable laying conditions, the length of the cables and the requirements of the local electricity supplier need to be considered.



Danger! **Supply voltage and missing earth connection!**

Important: ensure that the plant is connected to earth.

Do not use plug adapters at the power plug.

Possible replacement of the power plug must only be carried out by a qualified electrician.



DANGER! **Aftercooler safety thermo-switch!**

Qualified personnel should carry out the connection of the aftercooler safety thermo-switch to the air compressor.

Be sure to check that the air compressor is pressureless and not connected to the power supply.

Use the appropriate cable feedthroughs for the installation work.

8.7 Condensate drain



Danger!

Compressed air and condensate under pressure!

The condensate is discharged at system pressure.



The drain pipe needs to be secured.

Never direct the condensate drain pipe at persons.

The dryer is delivered with an already integrated timed condensate drain or an electronically level-controlled ZL Drain. Connect the condensate drain with a collection system or container by properly screwing it on.

Do not connect the drain with pressurised plants.



Do not discharge the condensate into the environment.

The condensate accumulating in the dryer contains oil particles which were released into the air by the compressor.

Dispose of the condensate in accordance with the local provisions.

It is advisable to install a water-oil separator, to which the total amount of condensate from the compressors, dryers, tanks, filters etc. is supplied.

We recommend Spremier Pure Oil-Water Separator for dispersed compressor condensate.

9 Start-up

9.1 Preliminary stages



Note!
Exceeding of the operating parameters!

Ensure that the operating parameters comply with the nominal values indicated on the name plate of the dryer (voltage, frequency, air pressure, air temperature, ambient temperature etc.).

Prior to delivery, this dryer was thoroughly tested, packed and checked. Please verify the soundness of the dryer during the initial start-up and check the perfect functioning during the first operating hours.



The initial start-up must be carried out by qualified personnel.

During the installation and operation of this device, all national regulations regarding electronics and any other federal and state ordinances, as well as local provisions, need to be adhered to.



The operator and the user must ensure that the dryer is not operated without panels.

9.2 Initial start-up



Note!

The dryer **must not be started up more than six times an hour**. Wait at least five minutes prior to every restart.

The user is responsible for the compliance with these provisions. Irreparable damage can be caused by starting up the device too often.



The method below should be applied during the first start-up, after longer downtimes or subsequent to maintenance works.

The start-up must be carried out by certified skilled personnel.

Processing sequence (see Section 11.1 "Control panel")

- Ensure that all the steps of the "Installation" chapter have been observed.
- Ensure that the connection to the compressed air system is correct and that the piping is suitably fixed and supported.
- Ensure that the condensate drain pipe is properly fastened and connected to a collection system or container.
- Ensure that the by-pass system (if installed) is open and the dryer is isolated
- Ensure that the manual valve of the condensate drain circuit is open.
- Remove any packaging and other material which could obstruct the area around the dryer.
- Activate the mains switch.
- Turn on the main switch - pos. 1 on the control panel.
- Ensure that the electronic instrument DMC34 is ON.
- Ensure the consumption matches with the values of the data plate.
- **Ensure the fan work properly - wait for its first interventions (Air-Cooled).**
- Allow the dryer temperature to stabilise at the pre-set value.
- Slowly open the air inlet valve.
- Slowly open the air outlet valve.
- Slowly close the central by-pass valve of the system (if installed).
- Check the piping for air leakage.
- Ensure the drain is regularly cycling - wait for its first interventions.

9.3 Start-up and shut down



Start-up (refer to paragraph 11.1 Control Panel)

- Check the condenser for cleanliness.
- Verify that the system is powered.
- Activate the main switch - pos. 1 on the control panel.
- Ensure that electronic controller DMC34 is ON.
- Wait a few minutes; verify that the DewPoint temperature displayed on electronic instrument DMC34 is correct and that the condensate is regularly drained.
- Switch on the air compressor.



Shut down (refer to paragraph 11.1 Control Panel)

- Verify that the DewPoint temperature displayed on electronic controller DMC34 is correct.
- Switch OFF the air compressor.
- After a few minutes, switch off the main switch on the control panel of the dryer (pos. 1).

NOTE : A DewPoint within 32°F (0°C) and +60°F (15°C) displayed on DMC34 is correct according to the possible working conditions (flow-rate, temperature of the incoming air, ambient temperature, etc.).

During the operation, the refrigerating compressor will run continuously. The dryer must remain on during the full usage period of the compressed air, even if the air compressor works intermittently.



The **number of starts must be no more than 6 per hour**. The dryer must stop running for at least 5 minutes before being started up again.

The user is responsible for compliance with these rules. Frequent starts may cause irreparable damage.

10 Technical data

10.1 Technical data SPRHT 20-T150T 1/115/60

MODEL	SPRHT	20T	30T	40T	50T	75T	100T	150T
Air flow rate at nominal condition (1)	[scfm]	20	30	40	50	75	100	150
	[l/min]	566	849	1132	1415	2123	2830	4245
	[m3/h]	34	51	68	85	127	170	255
Pressure DewPoint at nominal condition (1)	[°F (°C)]	45 (7)						
Nominal ambient temperature	[°F (°C)]	100 (38)						
Min...Max ambient temperature	[°F (°C)]	34 (1) ... 122 (50)						
Nominal inlet air temperature (max.)	[°F [°C]]	180 (210) [82 (100)]						
Nominal inlet air pressure	[psig (barg)]	100 (7)						
Max. inlet air pressure	[psig (barg)]	230 (16)						
Air pressure drop - Δp	[psi (bar)]	1,5 (0,10)	2,8 (0,19)	2,9 (0,20)	4,1 (0,28)	3,8 (0,26)	3,0 (0,21)	5,0 (0,35)
Inlet - Outlet connections	[NPT-F]	1/2"		1"		1,1/4"		
Refrigerant type		R134.a						
Refrigerant quantity (2)	[oz. (kg)]	7,41 (0,21)	7,76 (0,22)	8,82 (0,25)	9,17 (0,26)	13,40 (0,38)	17,64 (0,50)	
Cooling air fan flow	[cfm (m3/h)]	500 (290)						
Heat Rejection	[kW]	4.02	4.16	4.37	5.33	7.18	7.30	9.47
Standard Power Supply (2)	[Ph/V/Hz]	1/115/60						
Nominal electric consumption	[kW]	0.21	0.28	0.31	0.48	0.77	0.88	1.14
	[A]	2.3	2.5	3.1	4.8	8.3	8.7	10.4
Total input current	[A]	3.2	4.2	4.2	4.2	7.9	9.7	11.0
Minimum Circuit Ampacity (MCA)	[A]	3.8	5.1	5.1	5.1	9.6	11.7	13.4
Maximum rating of Overcurrent Protective device (MOP)	[A]	6.3	8.6	8.6	8.6	16.2	19.8	22.9
Fuse max.	[A]	6,1 / 4	8.0	8.0	8.0	15.0	15.0	20.0
Max. noise level at 1 m	[dba]	<70						
Weight	[lb (kg)]	66 (30)	68 (31)	71 (32)	73 (33)	110 (50)	134 (61)	146 (66)

(1) The nominal condition refers to an ambient temperature of 100°F (38°C) with inlet air at 100psig (7barg) and 100°F (38°C).

(2) Check the data shown on the identification plate.

MODEL	SPRHT	150T	200T	250T	300T	350T
Air flow rate at nominal condition (1)	[scfm]	150	200	250	300	350
	[l/min]	4245	5663	7079	8495	9911
	[m ³ /h]	255	340	425	510	595
Pressure DewPoint at nominal condition (1)	[°F (°C)]	45 (7)				
Nominal ambient temperature	[°F (°C)]	100 (38)				
Min...Max ambient temperature	[°F (°C)]	34 (1) ... 122 (50)				
Nominal inlet air temperature (max.)	[°F (°C)]	180 (210) [82 (100)]				
Nominal inlet air pressure	[psig (barg)]	100 (7)				
Max. inlet air pressure	[psig (barg)]	200 (14)				
Air pressure drop - Δp	[psi (bar)]	2,0 (0,14)	2,9 (0,20)	3,8 (0,26)	2,9 (0,20)	3,8 (0,26)
Inlet - Outlet connections	[NPT-F]	1,1/4" 1,1/2" 2"				
Refrigerant type		R407C				
Refrigerant quantity (2)	[oz. (kg)]	17,64 (0,50)	21,87 (0,62)	25,75 (0,73)	44,09 (1,25)	51,15 (1,45)
Cooling air fan flow	[cfm (m ³ /h)]	14.400	14.400	14.800	21.600	22.200
Heat Rejection	[kW]	23.40	24.10	31.90	42.10	54.70
Standard Power Supply (2)	[Ph/V/Hz]	1/230/60				
Nominal electric consumption	[kW]	1.14	1.28	1.57	2.13	2.68
	[A]	5.2	5.9	7.2	9.8	12.2
Total input current	[A]	5.8	6.2	6.3	10.4	13.1
Minimum Circuit Ampacity (MCA)	[A]	7.0	7.4	7.6	12.3	15.6
Maximum rating of Overcurrent Protective device (MOP)	[A]	11.7	12.1	12.5	19.9	25.9
Fuse max.	[A]	10.0	12.0	12.0	15.0	25.0
Max. noise level at 1 m	[dbA]	<80				
Weight	[lb (kg)]	146 (66)	165 (75)	185 (84)	291 (132)	304 (138)

(1) The nominal condition refers to an ambient temperature of 100°F (38°C) with inlet air at 100psig (7barg) and 100°F (38°C).

(2) Check the data shown on the identification plate.

11 Technical description

11.1 Control panel

The control panel explained below is the only dryer user interface.

SPRHT 20T – 300T

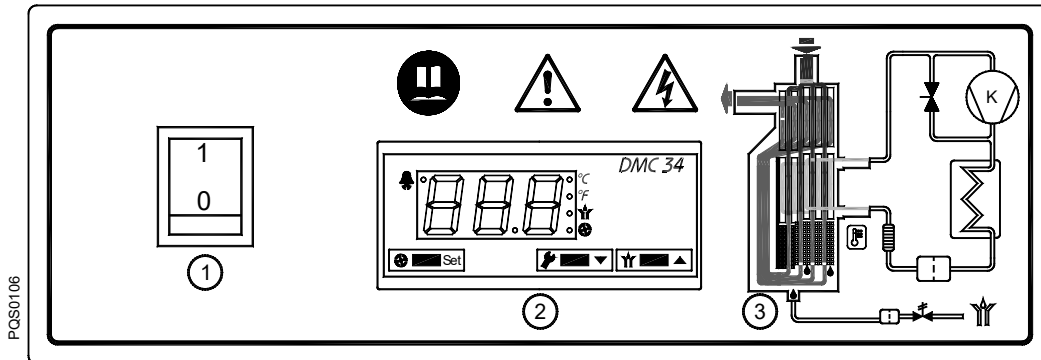

SPRHT 350T

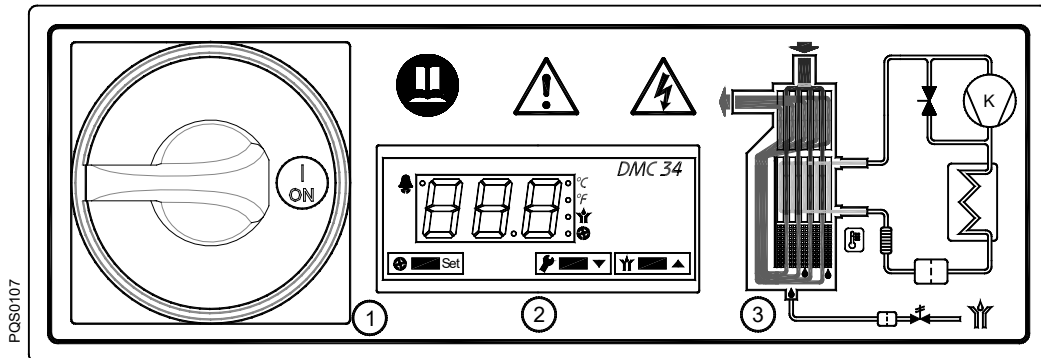

- 1 ON-OFF Switch
- 2 Electronic instrument
- 3 Air and refrigerant flow diagram

11.2 Functional description

Operating principle – The dryer models described in this manual all operate on the same principal. First the very hot moisture laden air directly from the compressor enters the aftercooler (copper tube / aluminum fin cooling surface) where it is cooled to within 18-20°F (10-12°C) of the ambient air temperature. It leaves the aftercooler with entrained condensed water droplets which are separated by the 1 micron bulk liquid filter separator element and drained away by the first drain system. The partially cooled moisture laden air next enters an air to air heat exchanger to pre-cool it. The compressed air next goes through the evaporator, also known as the air to refrigerant heat exchanger. The compressed air temperature is reduced to approximately 41°F (5°C), causing additional water vapor to condense to liquid. The liquid is continuously coalesced and collected in the dryer separator for automatic removal by the second condensate drain. The cool moisture free compressed air then passes back through the air to air heat exchanger to be reheated to within the ambient temperature as it exits the dryer.

Refrigeration cycle – Refrigerant gas is cycled through the compressor and exits at high pressure to a condenser where heat is removed causing the refrigerant to condense to a high-pressure liquid state. The liquid is forced through a capillary tube where the resulting pressure drop allows the refrigerant to boil off at a predetermined temperature. Low-pressure liquid refrigerant enters the heat exchanger where heat from the incoming air is transferred causing the refrigerant to boil; the resulting phase change produces a low pressure, low temperature gas. The low-pressure gas is returned to the compressor, where it is re-compressed and begins the cycle again. During those periods when the compressed air load is reduced the excess refrigerant is by-passed automatically back to the compressor via the Hot Gas By-pass Valve circuit.

11.3 Flow chart

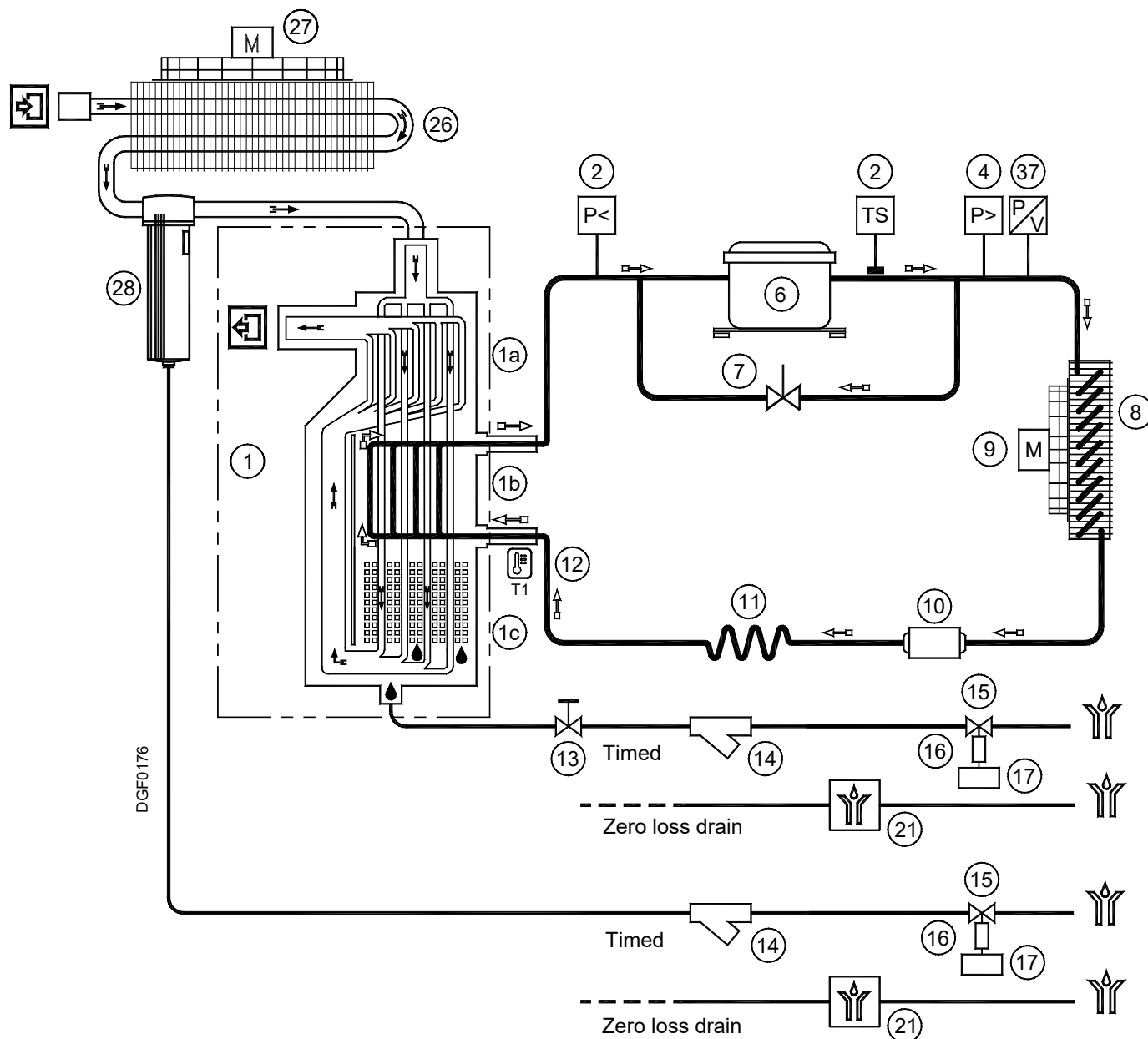

- | | |
|---|--|
| <p>1 Aluminium heat exchanger module
 a – Air/air heat exchanger
 b – Air/refrigerant heat exchanger
 c – Condensate separator</p> <p>2 Refrigerant pressure switch LPS (SPRHT 300T-350T)</p> <p>3 Safety temperature switch TS (SPRHT 150T-350T)</p> <p>3.1 Aftercooler safety thermo-switch TSA</p> <p>4 Refrigerant pressure switch HPS (SPRHT 300T-350T)</p> <p>6 Refrigerating compressor</p> <p>7 Hot-gas bypass valve</p> <p>8 Condenser</p> <p>9 Condenser fan</p> <p>10 Filter dryer</p> | <p>11 Capillary tube</p> <p>12 T1 temperature sensor (DewPoint)</p> <p>13 Condensate drain shut-off valve</p> <p>14 Condensate drain strainer</p> <p>15 Condensate drain solenoid valve</p> <p>16 Coil for condensate drain solenoid valve</p> <p>17 Electronic controller</p> <p>21 ZL Drain</p> <p>26 Aftercooler</p> <p>27 Aftercooler fan (SPRHT 75T-350T)</p> <p>28 Pre-Filter (1 micron)</p> <p>37 Pressure transducer BP2</p> |
|---|--|

→ Compressed-air flow direction

⇨ Refrigerant gas flow direction

Technical description

11.4 Refrigerating compressor

The employed refrigerating compressors are constructed by leading manufacturers. The hermetically sealed construction is absolutely gastight. The integrated safeguard protects the compressor against overheating and excess current. The protection is automatically reset as soon as the nominal conditions are reached again.

11.5 Condenser

The condenser is the component in which the gas coming from the compressor is cooled down, condensed and liquefied. Under no circumstances must the temperature of the ambient air exceed the nominal values. It is also important that the condenser unit is kept free from dust and other impurities.

11.6 Aftercooler

The aftercooler is the element where the incoming hot air undergoes the cooling stage. Mechanically, it is formed by a copper tubing circuit (with the compressed air flowing inside) immersed in an aluminium blades package. The cooling operation occurs via a high efficiency axial ventilator which, in applying pressure on the air contained within the dryer, forces it into the blades package. In models SPRHT 20T-50T the aftercooler is combined with the dryer's condenser, thus forming just one heat exchanger battery, cooled by just one high efficiency axial fan.

It is mandatory that the temperature of the ambient air will not exceed the nominal values of the dryer. It is important **TO KEEP THE UNIT FREE FROM DUST AND OTHER IMPURITIES** taken in by the fan.

11.7 Pre-Filter (1 micron)

Positioned at the outlet of the aftercooler, it assures a good air cleanliness level, in addition to the complete removal of the water condensed in the aftercooler. **REPLACE THE FILTERING ELEMENT (CARTRIDGE) AT LEAST EVERY 12 MONTHS.**

11.8 Filter dryer

Despite controlled vacuuming, traces of moisture can accumulate in the refrigeration cycle. The filter dryer serves to absorb this moisture and to bond it.

11.9 Capillary tube

The capillary tube is a copper tube with a reduced diameter which is located between the condenser and the evaporator, serving as a restrictor to reduce the pressure of the refrigerant. The pressure reduction serves to reach an optimum temperature inside of the evaporator. The lower the outlet pressure at the capillary tube, the lower the evaporation temperature.

The length and the inner diameter of the capillary tube are exactly dimensioned to ensure the performance of the dryer. Settings or maintenance works are not required.

11.10 Aluminium heat exchanger

The heat exchanger module consists of an air/air heat exchanger, an air/refrigerant heat exchanger, and of a high-performance separator. The compressed air flows top-down through the heat exchanger. The large cross-sections of the flow passages cause low flow rates and low compressed-air losses. In the air/air heat exchanger, the heat exchange is effected in a reverse current. This guarantees maximum heat transfer. The heat transfer in the air/refrigerant heat exchanger also takes place in a reverse current. This allows full evaporation of the refrigerant. The high-performance separator ensures almost complete separation of the condensate. Maintenance of the high-performance separator is not required.

11.11 Hot-gas bypass valve

At partial load, the valve directly returns a part of the hot gas to the suction line of the refrigerating compressor. The evaporation temperature and the evaporation pressure remain constant.



ADJUSTMENT

The hot gas by-pass valve is adjusted during the manufacturing testing phase. As a rule no adjustment is required; anyway if it is necessary the operation must be carried out by an experienced refrigerating engineer.

WARNING

the use of 1/4" Schrader service valves must be justified by a real malfunction of the refrigerating system. Each time a pressure gauge is connected, a part of refrigerant is exhausted.

Without compressed air flow through the dryer, rotate the adjusting screw (position A on the drawing) until the following value is reached:

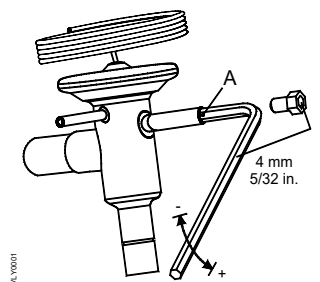

Hot gas setting (R134.a):

- temperature 33°F (+1 / -0 °F) [0.5°C (+0.5 / -0 °K)]
- pressure 29 psig (+1.45 / -0 psi) [2.0 barg (+0.1 / -0 bar)]

Hot gas setting (R407C) :

- temperature 33°F (+1 / -0 °F) [0.5 °C (+0.5 / -0 °K)]
- pressure 75.4 psig (+1.5 / -0 psi) [5.2 barg (+0.1 / -0 bar)]

11.12 Refrigerant pressure switches LPS – HPS

To ensure the operational reliability and the protection of the dryer, a series of pressure switches are installed in the gas cycle.

LPS : Low-pressure guard on the suction side of the compressor, which is triggered when the pressure drops below the predetermined value. The values are reset automatically as soon as the nominal conditions are re-established.

Calibrated pressure : R 407 C Stop 24.7 psig (1.7 barg) - Restart 39.2 psig (2.7 barg)

HPS : The high-pressure control unit on the discharge side of the compressor is activated when the pressure exceeds the predetermined value. It has a manual reset button on the control itself.

Calibrated pressure : R 407 C Stop 435 psig (30 barg) - Manual reset P<334 psi (P<23 bar)

11.13 Safety temperature switch TS

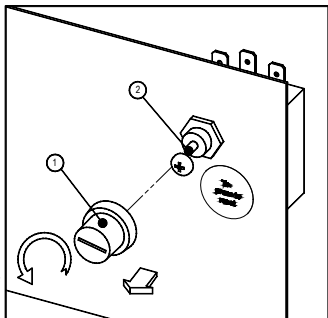

To ensure the operational safety and the soundness of the dryer, a safety temperature switch (TS) is installed at the refrigeration cycle. In the event that the pressure gas temperature is too high, the sensor of the temperature switch will stop the refrigerating compressor to prevent the pressure gas temperature getting too high.

The temperature switch is reset manually, but only when the normal operating conditions are reached again. Unscrew the cover (see pos. 1 in the illustration) and press the reset button (see position 2 in the illustration).

TS setting : temperature 235,4°F (+0/-10°F) [113°C (+0 / -6 °K)]

11.14 Aftercooler safety thermo-switch TSA

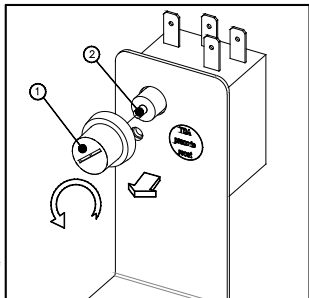

To guarantee the operating safety and the integrity of the dryer, an aftercooler thermo-switch (T_{SA}) is installed on the after cooler circuit. In case of unusual temperatures the thermo-switch sensor behind the after cooler, stops the air compressor.

T_{SA} setting : temperature 163,4°F (+0 / -10°F) [73 °C (+0 / -6 °K)]

11.15 Electronic controller DMC34

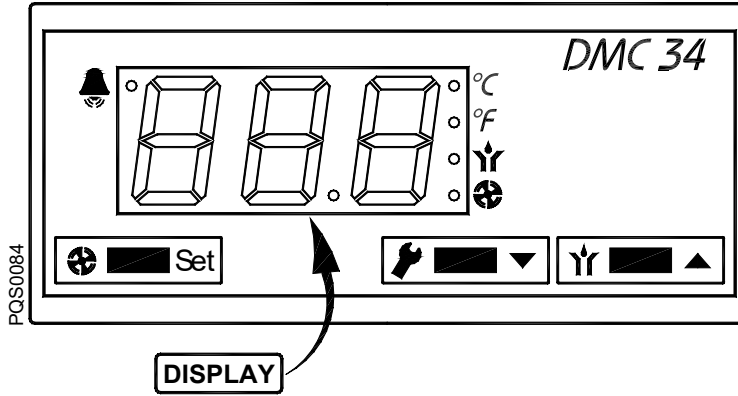

- °C Led - Temperature in °C
- °F Led - Temperature in °F
- Led – Drain ON
- Led – Fan ON
- Led – Alarm/Service
- Button – Setup menu access / Condensing
- Button – Decrease / Service
- Button – Increase / Drain test

The DMC34 displays DewPoint temperature, controls the condenser fan activation, handles a service reminder and keep record of the total hours of operation of the dryer.

11.15.1 How to switch on the dryer

Power the dryer and switch it on using the ON-OFF switch (pos. 1 paragraph 7.1).

During normal operation the display shows the DewPoint temperature.

The condensate drain test is always active using the button .

11.15.2 How to switch off the dryer

Switch it off using the ON-OFF switch (pos. 1 paragraph 7.1).

11.15.3 How to display the operating parameters

During normal operation, the display shows the DewPoint temperature (in °C or °F).

Press and hold button to display condensing pressure.

Press and hold button to display hours until the next service.

Press and hold + buttons to display total hours of operation of the dryer (cannot be reset).

NOTE : with led °C on temperatures are in °C and pressure in barg; with led °F on temperatures are in °F and pressure in psig.

The total hours of operation and the hours until the next service are shown in the field 0...999 hours and in thousands of hours from 01.0 hours on (example : if the display shows number 35 it means 35 hours; if the display shows number 3.5 it means 3500 hours).

11.15.4 How a service warning / alarm is displayed

A service warning / alarm is an unusual event that must recall the attention of the operators/maintenance technicians. It does not stop the dryer.

When a service warning / alarm is active, the led is lighted or flashing.

Service warnings / alarms are automatically reset as soon as the problem is solved and dryer is powered again. Scheduled Service reminder requires manual reset.

NOTE: the operator/maintenance technician must inspect the dryer and verify/solve the problem that generated the service warning.

Service Warning / Alarm	Description
flashing + PF 1 on display	PF1 - Probe 1 Failure : failure temperature probe BT1
flashing + PF 2 on display	PF2 - Probe 2 Failure : failure pressure probe BP2
flashing + HdP on display	HdP - High DewPoint: DewPoint too high Set BT1>HdS, delay Hdd / Reset BT1<HdS-1°C (HdS-2°F)
flashing + LdP on display	LdP - Low DewPoint : DewPoint too low Set BT1< -1°C (30°F), delay 5 minutes / Reset T1> 1°C (34°F)
flashing + SrV on display	SrV - Service : maintenance service time expired SrV

11.15.5 How is controlled the condenser fan

A pressure probe BP2 is located on the discharge side of the compressor. The condenser fan is activated (ON) when the BP2 pressure is higher than FANon setting (R134a approx. 11 barg/160 psig – R407C approx. 18 barg/260 psig) and led  is ON. Condenser fan stops when BP2 pressure is lower than FANoff setting (R134a approx. 8 barg/115 psig – R407C approx. 14 barg/203 psig).

11.15.6 How is controlled the drain solenoid valve

Drain solenoid valve is activated (ON) for *t_{on}* seconds (standard 2 seconds) every *t_{of}* minutes (standard 1 minute). Led  shows that condensate drain solenoid valve is ON.

The condensate drain test is always active using the button .

NOTE : if an electronic drainer is installed, DMC34 is set to keep always powered the drain output (*t_{on}* = ON).

11.15.7 How to reset the service reminder timer



With dryer OFF keep pressed buttons  + , power the dryer and switch it on using the ON-OFF switch (pos.1 paragraph 7.1).



After 5 seconds display shows *SRL*, release buttons  + , keep pressed button  for 5 seconds. Timer has been reset and controller start to operate regularly.

Service reminder timing can be reset at any time, even before the timing has expired.

11.15.8 Operation of the failure / alarm dry contact

The DMC34 is equipped with a dry contact (potential free) to display failure and/or alarm conditions.

  Dryer powered and no service warning / alarm is active.

  Dryer not powered or service warning / alarm is active.

Technical description

11.15.9 How to change the operating parameters

The setup menu can be used to change the dryer's operating parameters.



Only qualified personnel must be allowed to access to the setup menu. The manufacturer is not responsible for malfunctioning or failure due to modification to the operating parameters.

With dryer ON simultaneously press buttons + for at least 5 seconds to enter the setup menu.

Access to the menu is confirmed by message **ton** on the display (first parameter of menu).

Keep pressed to display the value of the selected parameter and use arrows and to change the value. Release the button to confirm the value and skip to following parameter.

Press + to exit setup menu (if no button is pressed after 2 minutes the menu is exited automatically).

ID	Description	Limits	Resolution	Standard setup
ton	Ton – drain time ON : time ON condensate drain valve ON = Electronic drainer installed	ON 00 ... 20 sec	1 sec	2
toF	ToF - drain time OFF : pause time for condensate drain valve	1 ... 20 min	1 min	1
HdS	HdS – High DewPoint Setting : Alarm threshold for a high DewPoint (the alarm disappears when the temperature drop 1°C / 2°F below alarm point)	0.0...25.0 °C or 32 ... 77 °F	0.5 °C or 1 °F	20 or 68
Hdd	Hdd - High DewPoint Delay : high DewPoint alarm enable delay	01 ... 20 minutes	1 min	15
SrL	SrV - Service Setting: setting of service warning timer. 00 = service warning timer disabled.	00.0 ... 20.0 (x 1000) hours	0.5 (x1000) hours	08.0
SrC	SrC – Service Contact : configuration of the alarm dry contact for the service warning timer. YES = activate the contact / NO = NOT activate the contact	YES / NO	-	YES
SCL	SCL - Scale: display scale of temperatures and pressure (°C = temperatures in °C and pressure in barg; °F = temperatures in °F and pressure in psig)	°C ... °F	-	°C

11.16 Electronic level controlled ZL Drain

The electronic level controlled ZL Drain has a special condensate management that makes sure that condensate is drained safely without any unnecessary air-loss. This drain consists of a condensate accumulator where a capacitive sensor continuously checking liquid level is placed: as soon as the accumulator is filled, the sensor passes a signal to the electronic control and a diaphragm solenoid valve will open to discharge the condensate. Right in time the discharge line will be closed again without wasting compressed air.

ATTENTION!

These ZL Drain have been specially designed for the use in a refrigerant dryer **SPRHT**. Any Installation in other compressed air treatment units or the exchange against a different drain brand may lead to malfunction. Do not exceed the max. operating pressure (see type plate)!

Make sure when the dryer starts the upstream valve is open.

NOTE:

For detailed information on drainer functions, troubleshooting, service and replacement parts, please refer to the ZL Drain manual.

12 Maintenance, troubleshooting, spare parts and dismantling

12.1 Checks and maintenance



Certified skilled personnel

Installation works must exclusively be carried out by authorised and qualified skilled personnel. Prior to undertaking any measures on the SPRHT 20T – 350T compressed-air refrigeration dryer, the certified skilled personnel³ shall read up on the device by carefully studying the operating instructions. The operator is responsible for the adherence to these provisions. The respective directives in force apply to the qualification and expertise of the certified skilled personnel.

For safe operation, the device must only be installed and operated in accordance with the indications in the operating instructions. In addition, the national and operational statutory provisions and safety regulations, as well as the accident prevention regulations required for the respective case of application, need to be observed during employment. This applies accordingly when accessories are used.



Danger!

Compressed air!

Risk of serious injury or death through contact with quickly or suddenly escaping compressed air or through bursting and/or unsecured plant components.

Compressed air is a highly dangerous energy source.

Never work on the dryer when the system is under pressure.

Never direct the compressed-air outlet or condensate drain hoses at persons.

The user is responsible for the proper maintenance of the dryer. Non-observance of the instructions in the "Installation" and "Maintenance, troubleshooting, spare parts and dismantling" chapters leads to the expiration of the guarantee. Improper maintenance may result in dangerous situations for the personnel and/or the device.



Danger!

Supply voltage!

Contact with non-insulated parts carrying supply voltage involves the risk of an electric shock resulting in injuries and death.

Only qualified and skilled personnel are authorised to run electrically-operated devices. Prior to undertaking maintenance measures at the device, the following requirements must be met:

Make sure that the power supply is switched off and that the device is off and marked for maintenance measures. Please also ensure that the power supply cannot be re-established during the works.



Prior to carrying out maintenance works at the dryer, switch it off and wait for at least 30 minutes.



Caution!

Hot surfaces!

During operation, several components can reach surface temperatures of more than 140°F (60°C). There is the risk of burns.

All components concerned are installed inside of the closed housing. The housing must only be opened by certified skilled personnel.

Some components can reach high temperatures during operation. Avoid any contact until the system or the component has cooled down.

³ Certified skilled personnel are persons who are authorised by the manufacturer, with experience and technical training, who are well-grounded in the respective provisions and laws and capable of carrying out the required works and of identifying and avoiding any risks during the machine transport, installation, operation and maintenance. Qualified and authorised operators are persons who are instructed by the manufacturer regarding the handling of the refrigeration system, with experience and technical training, and who are well-grounded in the respective provisions and laws.



DAILY:

- Check whether the dew point indicated on the electronics is correct.
- Ensure that the condensate drain system functions properly.
- Make sure that the condenser is clean.

EVERY 200 HOURS OR MONTHLY



- Clean the condenser using an air jet (max. 2 bar / 30 psig) inside out. Make sure not to damage the aluminium lamellae of the cooling package.
- Finally, verify the operation of the device.



EVERY 1000 HOURS OR YEARLY

- Verify for tightness all the screws of the electric system and that all the “Faston” type connections are in their proper position, inspect unit for broken, cracked or bare wires.
- Inspect refrigerating circuit for signs of oil and refrigerant leakage.
- Measure and record amperage. Verify that readings are within acceptable parameters as listed in specification table.
- Inspect condensate drain flexible hoses, and replace if necessary.
- Replace the filter element (cartridge) of the Pre-Filter (1 micron). Refer to the instructions in the user’s and maintenance manual of the filter for this operation.
- At the end, check the operation of the machine.



EVERY 8,000 HOURS

- Replace ZL Drain Service Unit.

12.3 Troubleshooting

**Certified skilled personnel**

Installation works must exclusively be carried out by authorised and qualified skilled personnel. Prior to undertaking any measures on the SPRHT 20T – 350T compressed-air refrigeration dryer, the certified skilled personnel shall read up on the device by carefully studying the operating instructions. The operator is responsible for the adherence to these provisions. The respective directives in force apply to the qualification and expertise of the certified skilled personnel.

For safe operation, the device must only be installed and operated in accordance with the indications in the operating instructions. In addition, the national and operational statutory provisions and safety regulations, as well as the accident prevention regulations required for the respective case of application, need to be observed during employment. This applies accordingly when accessories are used.

**Danger!****Compressed air!**

Risk of serious injury or death through contact with quickly or suddenly escaping compressed air or through bursting and/or unsecured plant components.

Compressed air is a highly dangerous energy source.

Never work on the dryer when the system is under pressure.

Never direct the compressed-air outlet or condensate drain hoses at persons.

The user is responsible for the proper maintenance of the dryer. Non-observance of the instructions in the "Installation" and "Maintenance, troubleshooting, spare parts and dismantling" chapters leads to the expiration of the guarantee. Improper maintenance may result in dangerous situations for the personnel and/or the device.

**Danger!****Supply voltage!**

Contact with non-insulated parts carrying supply voltage involves the risk of an electric shock resulting in injuries and death.

Only qualified and skilled personnel are authorised to run electrically-operated devices. Prior to undertaking maintenance measures at the device, the following requirements must be met:

Make sure that the power supply is switched off and that the device is off and marked for maintenance measures. Please also ensure that the power supply cannot be re-established during the works.



Prior to carrying out maintenance works at the dryer, switch it off and wait for at least 30 minutes.

**Caution!****Hot surfaces!**





During operation, several components can reach surface temperatures of more than 140°F (60°C). There is the risk of burns.

All components concerned are installed inside of the closed housing. The housing must only be opened by certified skilled personnel.

Some components can reach high temperatures during operation. Avoid any contact until the system or the component has cooled down.

Maintenance, troubleshooting, spare parts and dismantling

FAULT	POSSIBLE REASON – SUGGESTED MEASURE
◆ The dryer does not start.	<ul style="list-style-type: none"> ⇒ Check whether or not the dryer is connected with the electric mains. ⇒ Check the electric cabling.
◆ The refrigerating compressor does not work.	<ul style="list-style-type: none"> ⇒ The internal heat protection of the compressor was activated – wait 30 minutes and then retry. ⇒ Check the electric cabling. ⇒ If installed – replace the internal heat protection and/or the start-up relay and/or the starting capacitor and/or the operating capacitor. ⇒ If installed – the HPS pressure switch was activated – see the corresponding point. ⇒ If installed – the LPS pressure switch was activated – see the corresponding point. ⇒ If installed – the TS safety temperature switch was activated – see the corresponding point. ⇒ If installed – the power contactor KC1 does not work, replace it. ⇒ In the event that the compressor still does not work, replace it.
◆ The fan of the condenser does not work	<ul style="list-style-type: none"> ⇒ Verify the electric wiring. ⇒ The electronic controller is faulty – replace it. ⇒ If installed - Fan relay (see KF on the electric diagram) is faulty - replace it. ⇒ There is a leak in the refrigerant circuit - contact a refrigeration engineer. ⇒ If the fan still doesn't work, replace it.
◆ DewPoint too high.	<ul style="list-style-type: none"> ⇒ The dryer doesn't start - see specific point. ⇒ The BT1 DewPoint probe doesn't correctly detect the temperature - ensure the sensor is pushed into the bottom of copper tube immersion well. ⇒ The refrigerating compressor doesn't work - see specific point. ⇒ The ambient temperature is too high or the room aeration is insufficient - provide proper ventilation. ⇒ The inlet air is too hot - restore the nominal conditions. ⇒ The inlet air pressure is too low - restore the nominal conditions. ⇒ The inlet air flow rate is higher than the rate of the dryer - reduce the flow rate - restore the normal conditions. ⇒ The condenser is dirty - clean it. ⇒ The aftercooler is dirty - clean it. ⇒ The condenser fan doesn't work - see specific point. ⇒ The aftercooler fan doesn't work - see specific point. ⇒ The dryer doesn't drain the condensate - see specific point. ⇒ The hot gas by-pass valve is out of setting - contact a refrigeration engineer to restore the nominal setting. ⇒ There is a leak in the refrigerating fluid circuit - contact a refrigeration engineer.
◆ The air compressor doesn't work.	<ul style="list-style-type: none"> ⇒ Verify the electric wiring. ⇒ Verify that the air thermo-switch is working properly ⇒ If the air compressor still doesn't work see troubleshooting of the air compressor
◆ DewPoint too low.	<ul style="list-style-type: none"> ⇒ The fan is always ON – Led  is flashing + display PF2 - see specific point. ⇒ Ambient temperature is too low - restore nominal conditions. ⇒ The hot gas by-pass valve is out of setting - contact a refrigeration engineer to restore nominal setting.
◆ Excessive pressure drop within the dryer.	<ul style="list-style-type: none"> ⇒ The Pre-Filter (1 micron) is clogged - replace the filter element (cartridge) - Refer to the instructions in the user's and maintenance manual of the filter. ⇒ The dryer doesn't drain the condensate - see specific point. ⇒ The DewPoint is too low - the condensate is frost and blocks the air - see specific point. ⇒ Check for throttling the flexible connection hoses.
◆ The dryer doesn't drain the condensate.	<ul style="list-style-type: none"> ⇒ The condensate drain service valve is closed - open it. ⇒ Verify the electric wiring. ⇒ The DewPoint is too low - the condensate is frozen - see specific point. ⇒ ZL Drain is not operating correctly (see ZL Drain MANUAL)
◆ The dryer continuously drains condensate.	<ul style="list-style-type: none"> ⇒ ZL Drain is dirty (see ZL Drain MANUAL)
◆ Water within the line.	<ul style="list-style-type: none"> ⇒ The dryer doesn't start - see specific point. ⇒ Where installed - Untreated air flows through the by-pass unit - close the by-pass. ⇒ The dryer doesn't drain the condensate - see specific point. ⇒ DewPoint too high - see specific point.

<p>◆ Where installed - The HPS high-pressure switch has been activated.</p>	<p>⇒ Check which of the following has caused the activation :</p> <ol style="list-style-type: none"> 1. The ambient temperature is too high or the room aeration is insufficient - provide proper ventilation. 2. The condenser is dirty - clean it. 3. The condenser fan doesn't work - see specific point. <p>⇒ Reset the pressure-switch pressing the button on the controller itself - verify the dryer for correct operation.</p> <p>⇒ The HPS pressure switch is faulty - contact a refrigeration engineer to replace it.</p>
<p>◆ Where installed - The LPS low-pressure switch has been activated.</p>	<p>⇒ There is a leak in the refrigerating fluid circuit - contact a refrigeration engineer.</p> <p>⇒ The pressure switch restores automatically when normal conditions are restored - check the proper operation of the dryer.</p>
<p>◆ Where installed - The TS safety thermo-switch has been activated.</p>	<p>⇒ Check which of the following has caused the activation :</p> <ol style="list-style-type: none"> 1. Excessive thermal load – restore the standard operating conditions. 2. The inlet air is too hot - restore the nominal conditions. 3. The ambient temperature is too high or the room aeration is insufficient - provide proper ventilation. 4. The condenser unit is dirty - clean it. 5. The fan doesn't work - see specific point. 6. There is a leak in the refrigerating fluid circuit - contact a refrigeration engineer. <p>⇒ Reset the thermo-switch by pressing the button on the thermo-switch itself – verify the correct operation of the dryer.</p> <p>⇒ The TS thermo-switch is faulty - replace it.</p>
<p>◆ DMC34 – Led  is flashing + display PF1.</p>	<p>⇒ Verify the electric wiring of BT1 DewPoint probe.</p> <p>⇒ The BT1 DewPoint probe is faulty - replace it.</p> <p>⇒ The electronic controller is faulty - replace it.</p>
<p>◆ DMC34 – Led  is flashing + display PF2.</p>	<p>⇒ Verify the electric wiring of BP2 fan control probe.</p> <p>⇒ The BP2 fan control probe is faulty - replace it.</p> <p>⇒ The electronic controller is faulty - replace it.</p>
<p>◆ DMC34 – Led  is flashing + display HdP.</p>	<p>⇒ DewPoint too high - see specific point.</p> <p>⇒ The BT1 DewPoint probe is faulty - replace it.</p> <p>⇒ The electronic controller is faulty - replace it.</p>
<p>◆ DMC34 – Led  is flashing + display LdP.</p>	<p>⇒ DewPoint too low - see specific point.</p> <p>⇒ The BT1 DewPoint probe is faulty - replace it.</p> <p>⇒ The electronic controller is faulty - replace it.</p>
<p>◆ DMC34 – Led  is flashing + display SrL.</p>	<p>⇒ Service reminder timer has expired – dryer requires service.</p> <p>⇒ Perform the proper service to the dryer.</p> <p>⇒ Reset the service reminder timer.</p>

Maintenance, troubleshooting, spare parts and dismantling

12.4 Recommended spare parts

Spare parts list is printed on a dedicated sticker applied inside the dryer. On this sticker each spare part is identified with its ID Number and related Spare Part Number. Here below the cross reference table between ID Numbers and exploded drawings Ref. with their description and quantity installed in the dryers.

ID N.		DESCRIPTION	SPRHT											
			20T	30T	40T	50T	75T	100T	150T	200T	250T	300T	350T	
2	LPS	Pressure switch											1	1
3	TS	Safety thermo switch											1	1
3.1	TSA	Aftercooler safety thermo switch	1	1	1	1	1	1	1	1	1	1	1	1
4	HPS	Pressure switch											1	1
6	MC	Compressor	1	1	1	1	1	1	1	1	1	1	1	1
7		Hot gas by-pass valve	1	1	1	1	1	1	1	1	1	1	1	1
8		Condenser	1	1	1	1	1	1	1	1	1	1	1	1
9	MV1	Complete fan											1	1
9.1		Fan motor	1	1	1	1	1	1	1	1	1			
9.2		Fan blade	1	1	1	1	1	1	1	1	1			
9.3		Fan grid	1	1	1	1	1	1	1	1	1			
10		Filter drier	1	1	1	1	1	1	1	1	1	1	1	1
12	BT	Temperature probe	1	1	1	1	1	1	1	1	1	1	1	1
13-14		Y strainer	1	1	1	1	1	1	1	1	1	1	1	1
15	EVD	Condensate drain solenoid valve	1	1	1	1	1	1	1	1	1	1	1	1
16		Coil for condensate drain solenoid valve	1	1	1	1	1	1	1	1	1	1	1	1
17	DMC34	Electronic instrument	1	1	1	1	1	1	1	1	1	1	1	1
21	ELD	ZL Drain	1	1	1	1	1	1	1	1	1	1	1	1
		ZL Drain service unit	1	1	1	1	1	1	1	1	1	1	1	1
22	S1	Lighted switch	1	1	1	1	1	1	1	1	1	1	1	1
	QS	Main switch								1	1	1	1	1
26		Aftercooler					1	1	1	1	1	1	1	1
27	MV2	Aftercooler fan								1	1	1	1	1
27.1		Fan motor					1	1	1					
27.2		Fan blade					1	1	1					
27.3		Fan grid					1	1	1					
28		Fine coalescing filter cartridge	1	1	1	1	1	1	1	1	1	1	1	1
37	BP2	Pressure transducer	1	1	1	1	1	1	1	1	1	1	1	1
60	KC1	Power contactor								1	1	1	1	1

12.5 Maintenance works at the refrigeration cycle



Caution! Refrigerant!

Maintenance and repair works at refrigeration systems must only be carried out by service technicians in accordance with the local provisions.

The total amount of refrigerant in the system must be collected for recycling purposes, resource recovery or disposal.

The refrigerant must not be discharged into the environment.

When delivered, the dryer is ready to operate and filled with a refrigerant of the R134a or R407C type.



Should you detect a refrigerant leak, please contact a service technician. Prior to any intervention, the room needs to be ventilated.

When the refrigeration cycle needs to be refilled, please also contact a service technician.

You will find the refrigerant type and amount on the name plate of the dryer.

Properties of the refrigerants used:

Refrigerant	Chemical formula	MIK	GWP
R134a - HFC	CH ₂ FCF ₃	1000 ppm	1430
R407C - HFC	R32/125/134a (23/25/52) CHF ₂ CF ₃ /CH ₂ F ₂ /CH ₂ FCF ₃	1000 ppm	1773,85

12.6 Dismantling the dryer

When the dryer is dismantled, all parts and operating materials related to the plant need to be disposed of separately.



Component	Material
Refrigerant	R407C, R134a, oil
Roof and supports	Structural steel, epoxy paint coat
Refrigerating compressor	Steel, copper, aluminium, oil
Aluminium heat exchanger	Aluminium
Condenser unit	Aluminium, copper, structural steel
Pipe	Copper
Fan	Aluminium, copper, steel
Valve	Brass, steel
ZL Drain	PVC, aluminium, steel
Insulant	Synthetic rubber without CFCs, polysterene, polyurethane
Electric cable	Copper, PVC
Electric parts	PVC, copper, brass



We recommend observing the safety provisions in force for the disposal of each material type.

The refrigerant contains lubricating-oil droplets which are released by the compressor.

The refrigerant must not be discharged into the environment. It must be sucked off from the dryer using a suitable device, and then needs to be supplied to a collection point.

13 Appendices

13.1 Dryer dimensions

13.1.1 Dryer dimensions SPRHT 20T-50T

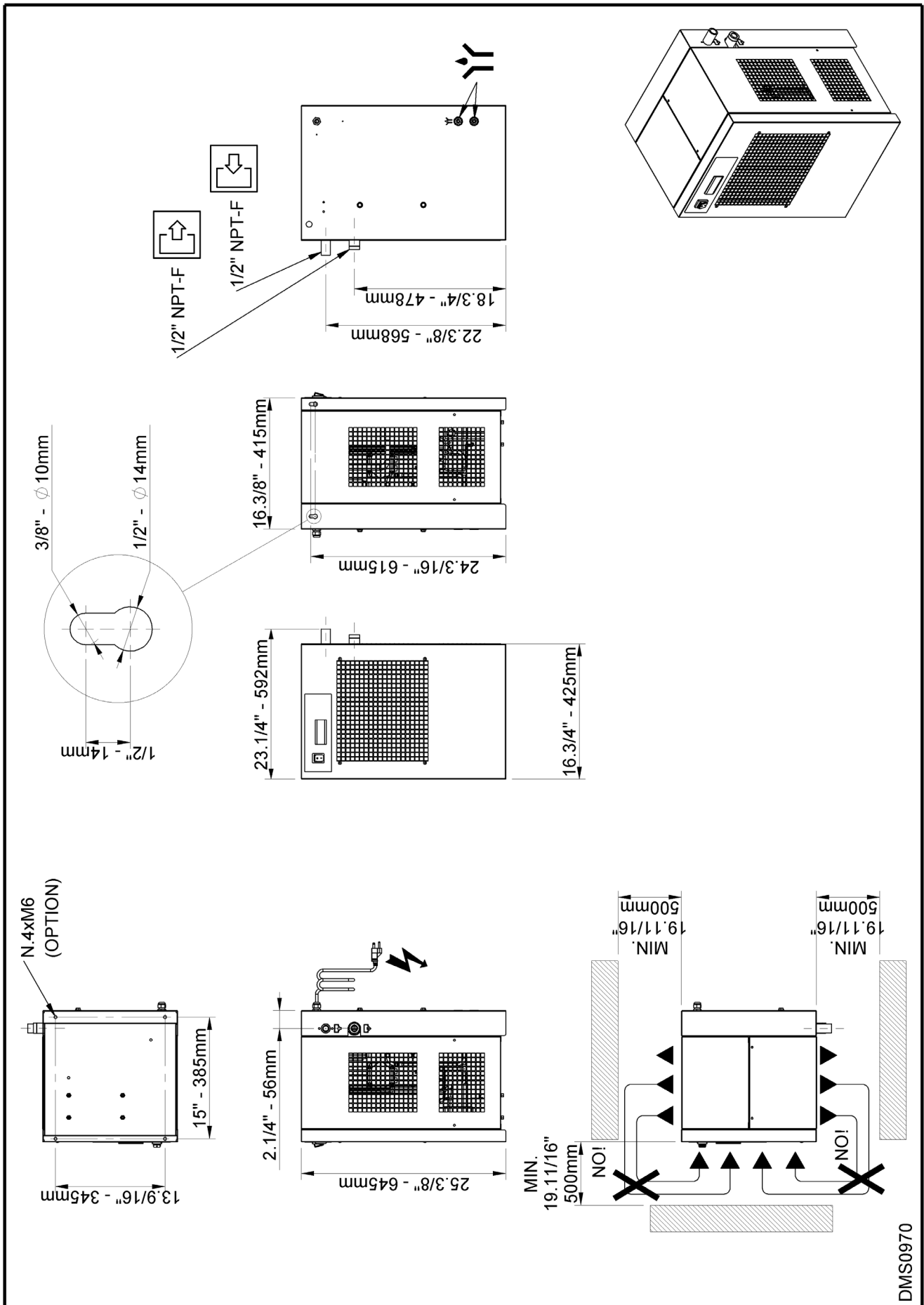

DMS0970

13.1.2 Dryers Dimensions SPRHT 75T

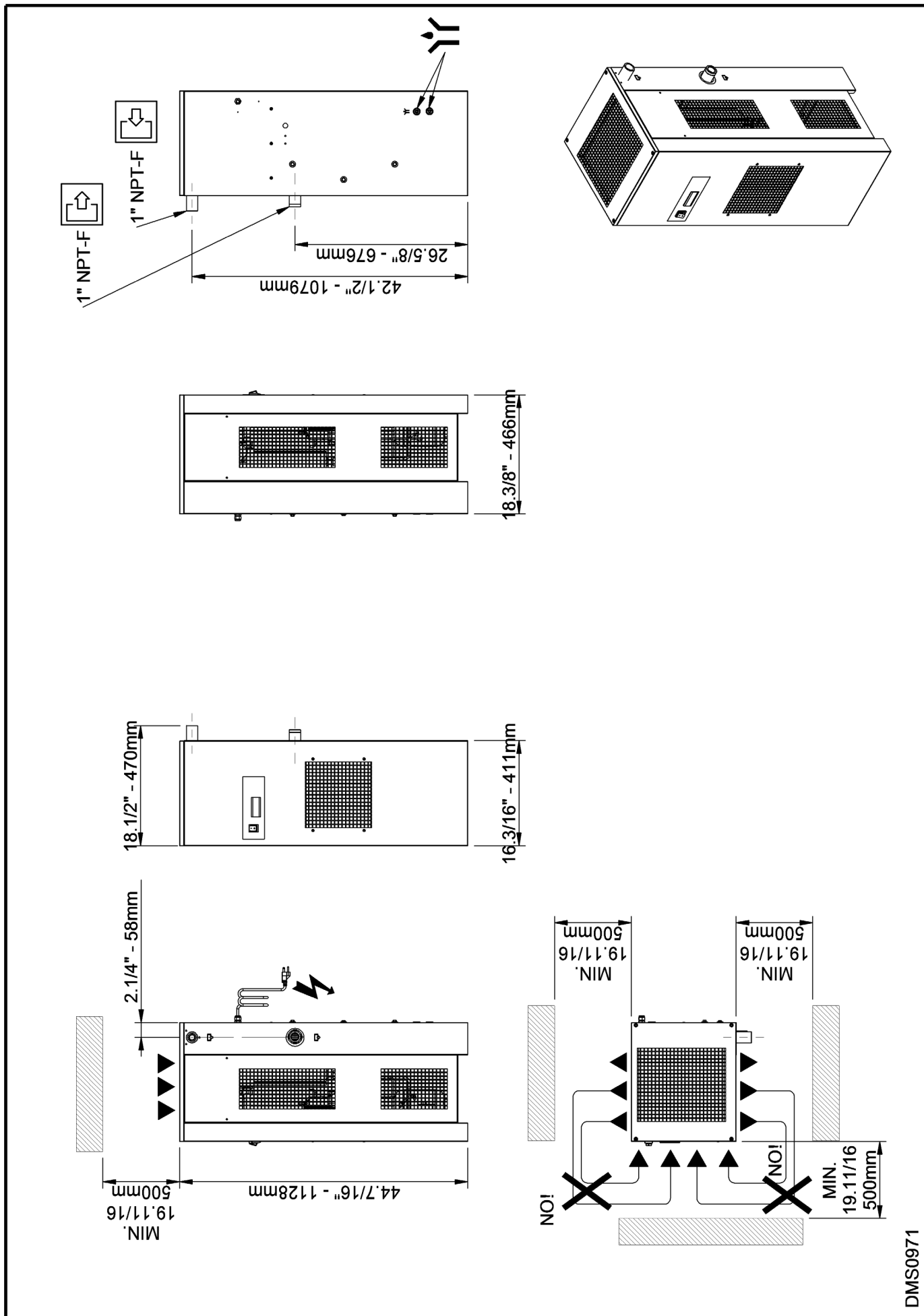

DMS0971

13.1.3 Dryer dimensions SPRHT 100T

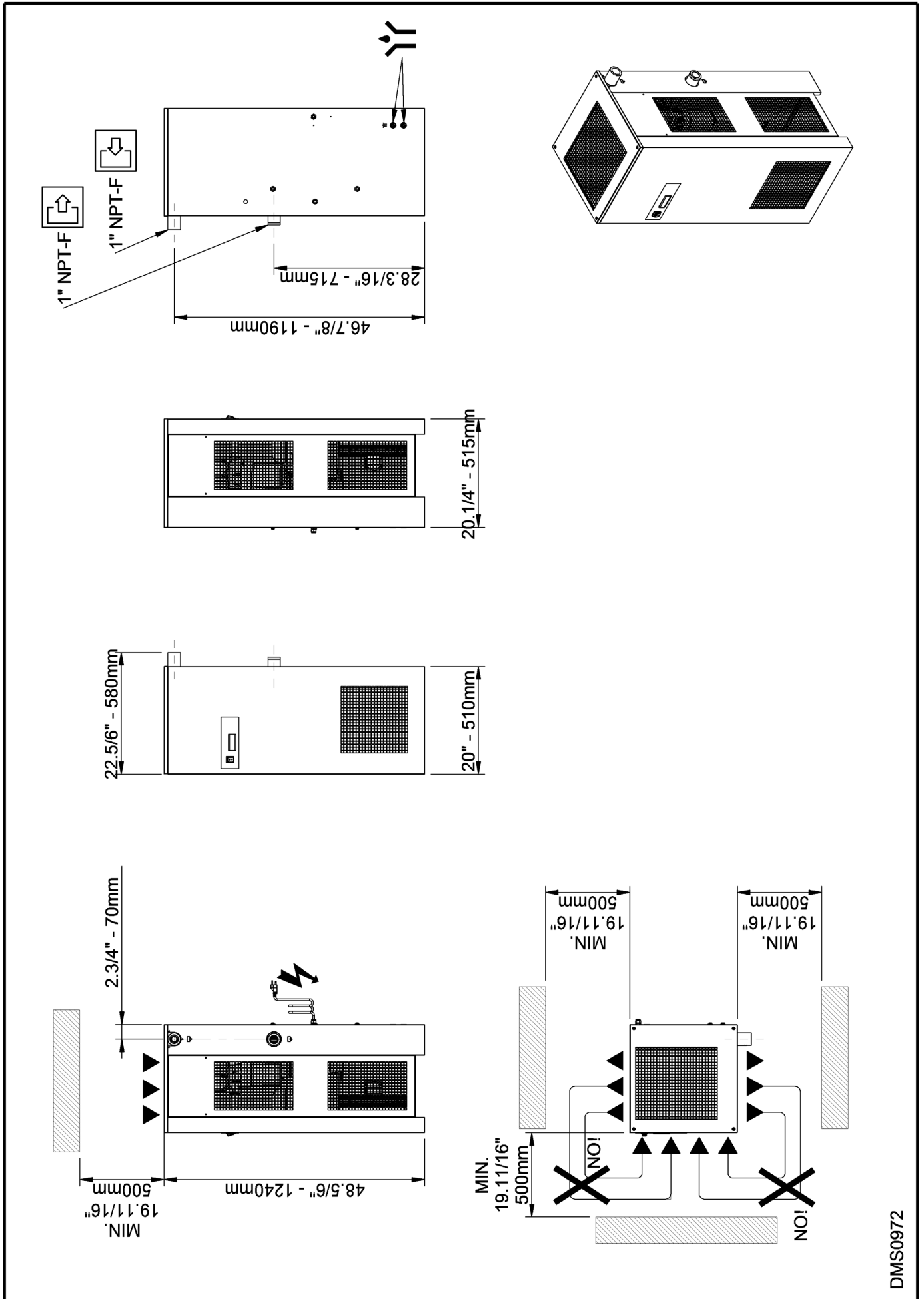

DMS0972

13.1.4 Dryer dimensions SPRHT 150T

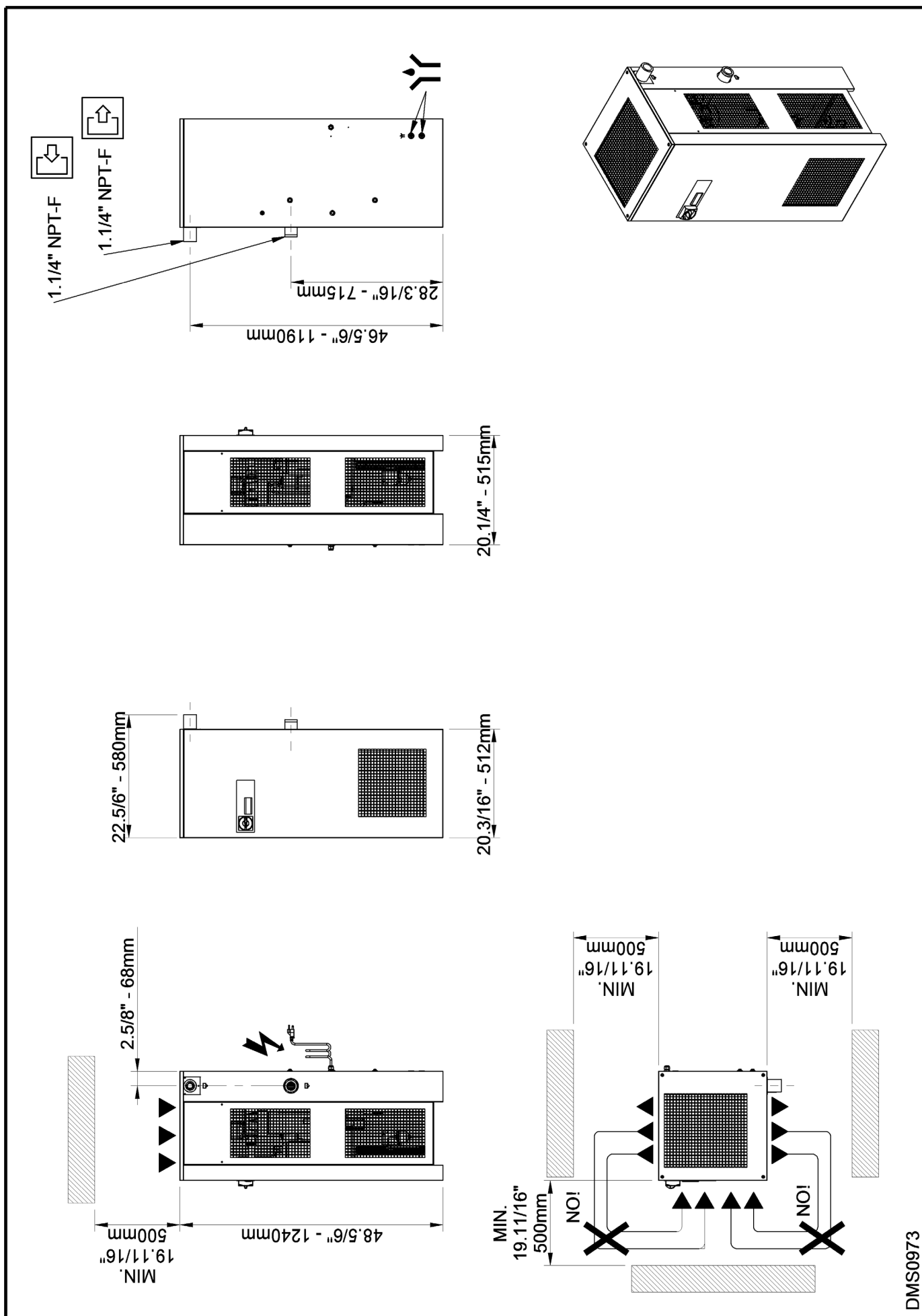

DMS0973

13.1.5 Dryers Dimensions SPRHT 200T-250T

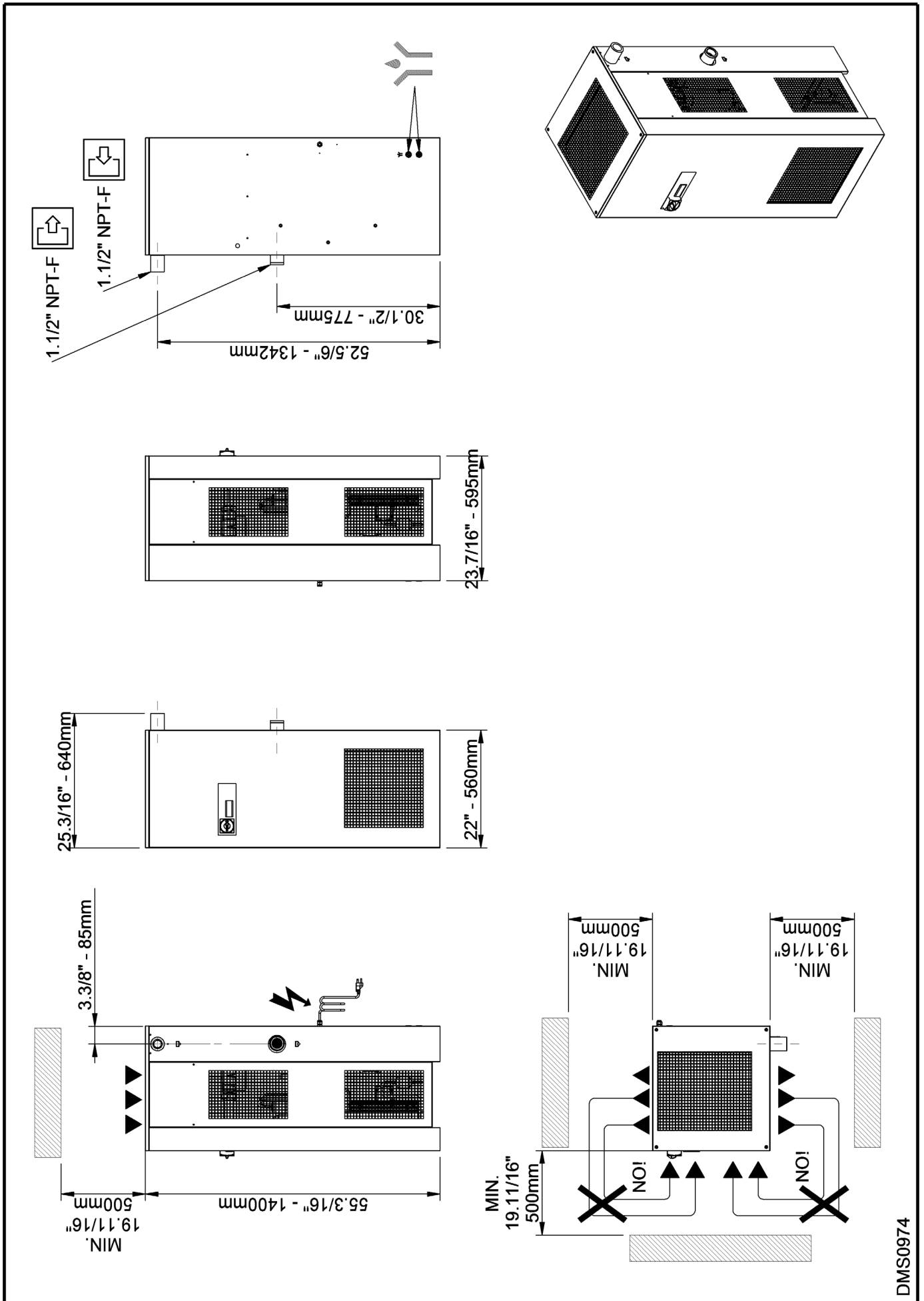

DMS0974

13.1.6 Dryers Dimensions SPRHT 300T-350T

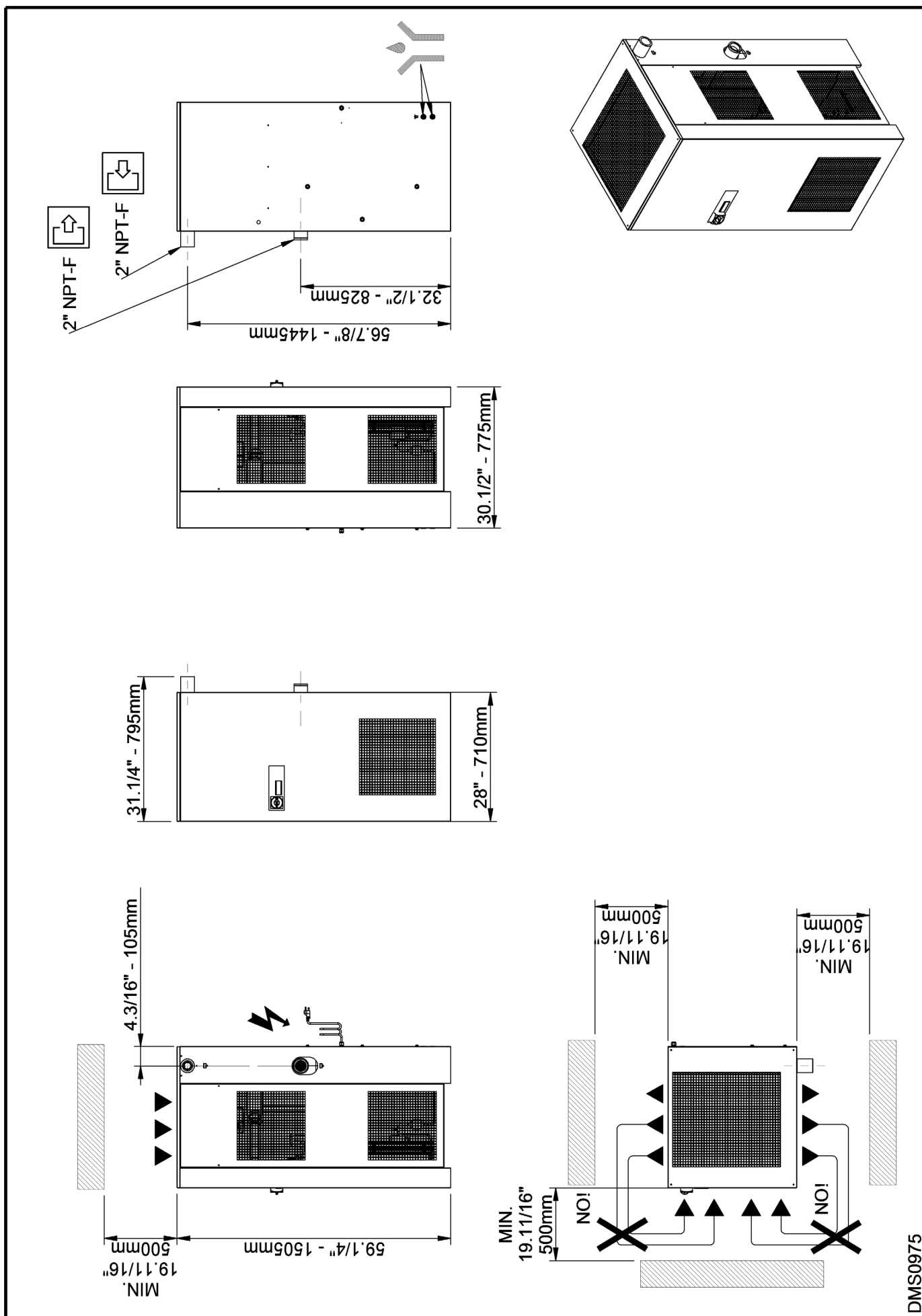

DMS0975

13.2 Exploded diagrams**13.2.1 Components of the exploded diagrams**

1	Alu drying module	22	Main switch
1.1	Insulation material	26	Aftercooler
2	Refrigerant pressure switch LPS	27	Aftercooler fan
3	Safety temperature switch TS		27.1 Motor
3.1	Aftercooler safety thermo-switch TSA		27.2 Blade
4	Refrigerant pressure switch HPS		27.3 Grid
6	Compressor	28	Pre-Filter
7	Hot-gas bypass valve	37	Pressure transducer BP2
8	Condenser	51	Front panel
9	Condenser fan	52	Back panel
	9.1 Motor	53	Right lateral panel
	9.2 Blade	54	Left lateral panel
	9.3 Grid	55	Cover
10	Filter dryer	56	Base plate
11	Capillary tube	57	Upper plate
12	T1 temperature probe (DewPoint)	58	Support beam
13	Condensate drain service valve	59	Support bracket
14	Condensate drain strainer	60	Control panel
15	Condensate drain solenoid valve	61	Electric connecting plug
16	Coil for condensate drain solenoid valve	81	Adhesive label flow chart
17	Electronic controller		
21	ZL Drain		

13.2.2 Exploded diagram SPRHT 20T-50T

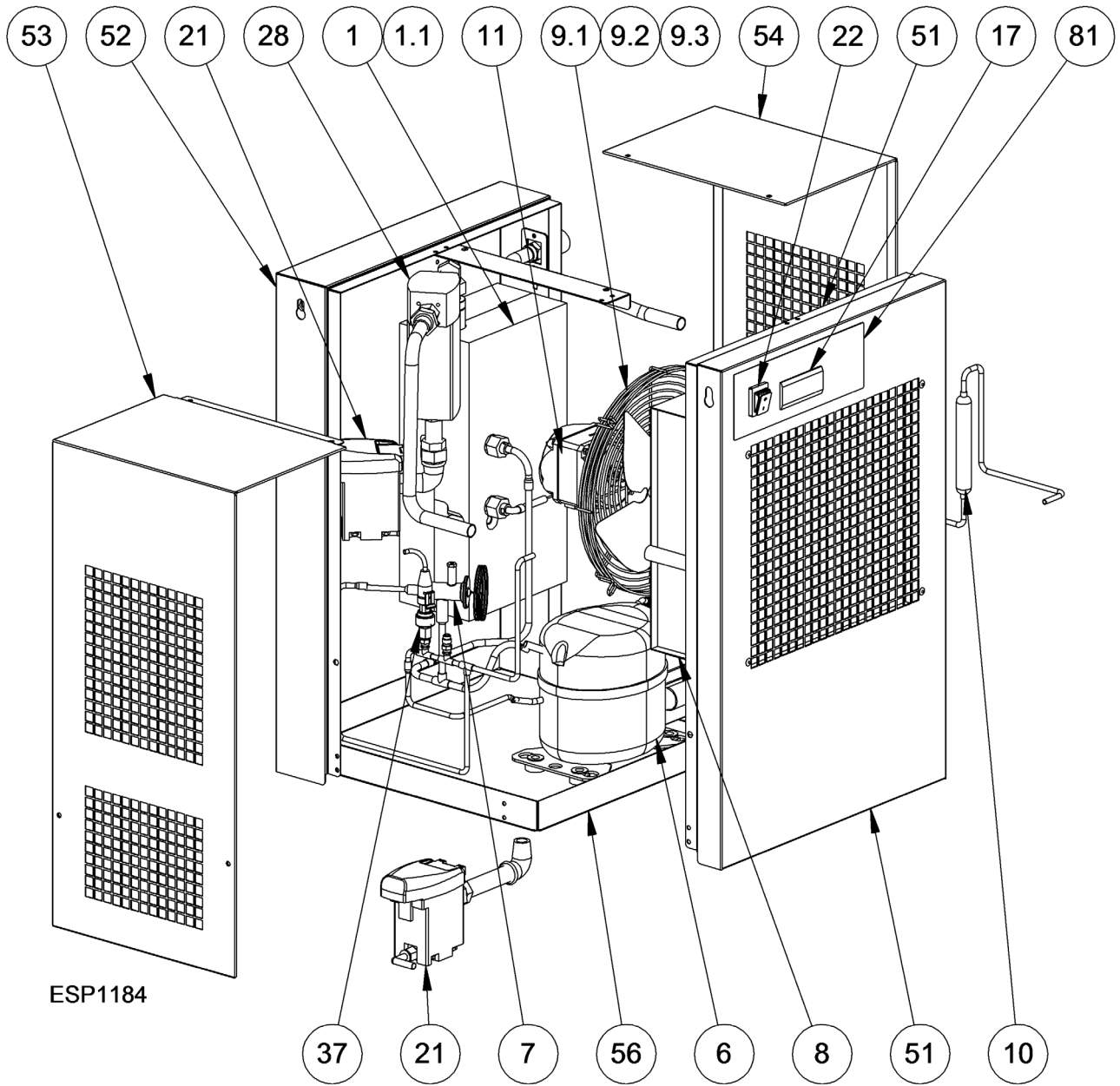

13.2.3 Exploded diagram SPRHT 75T

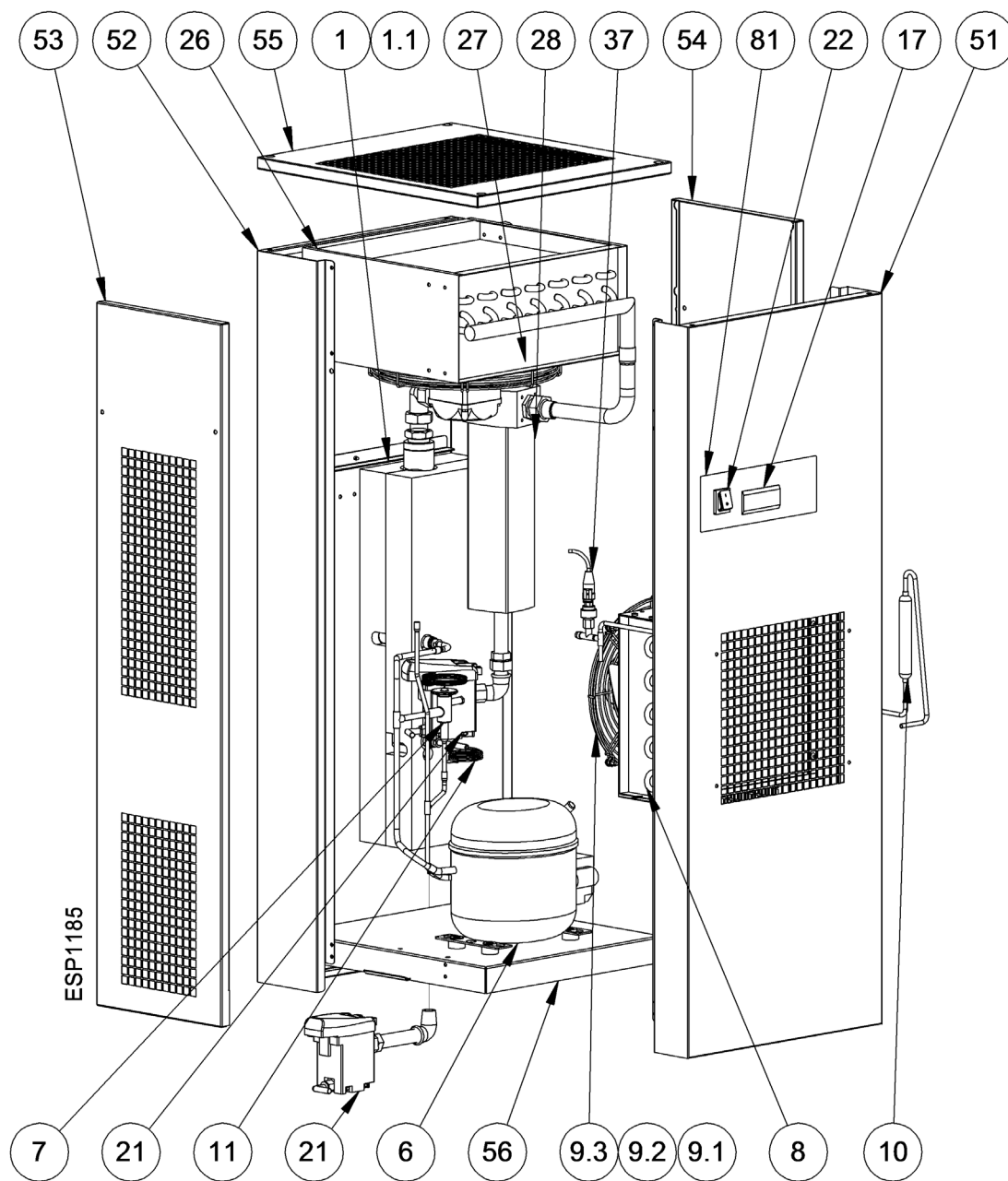

13.2.4 Exploded diagram SPRHT 100T

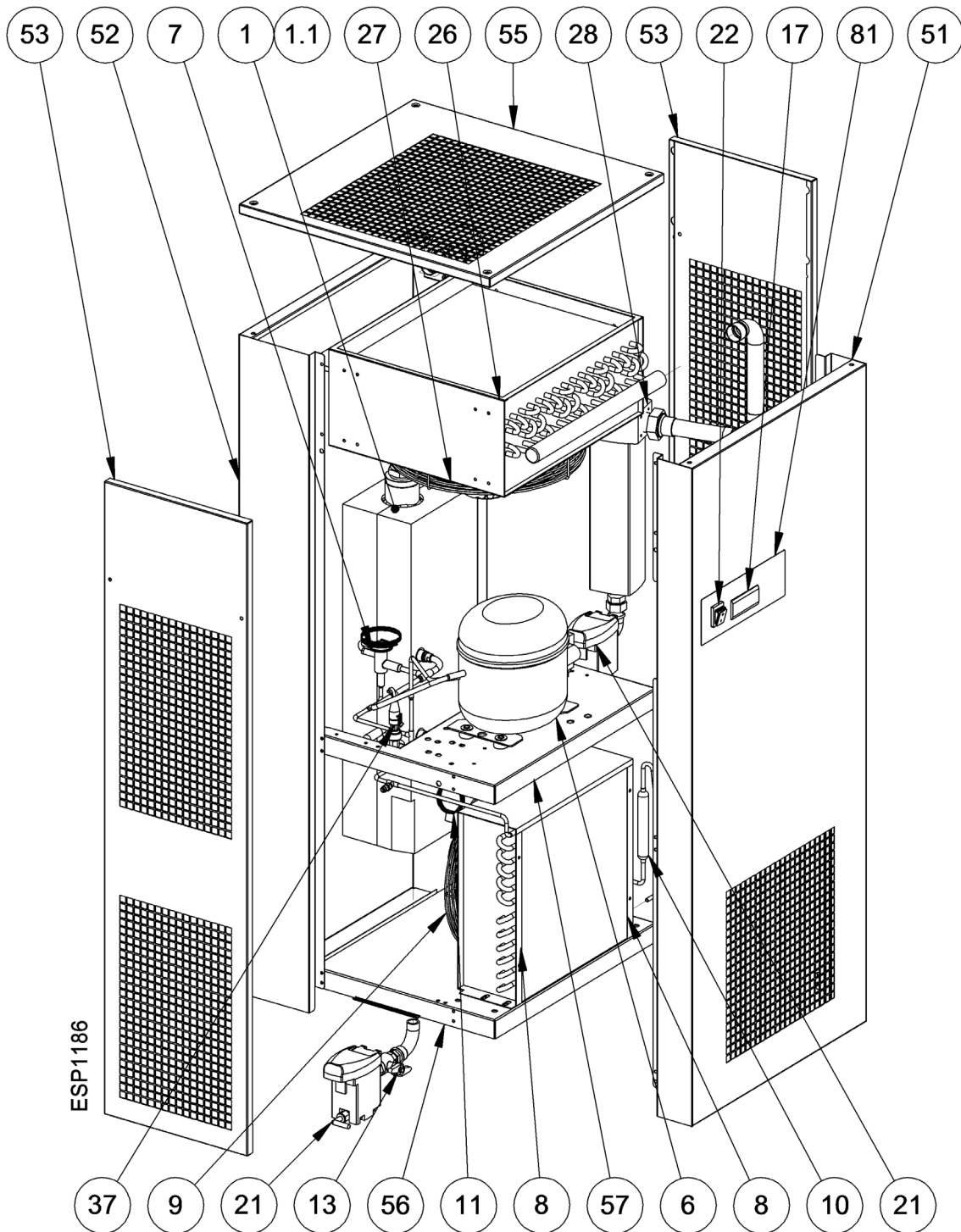

13.2.5 Exploded diagram SPRHT 150T-200T

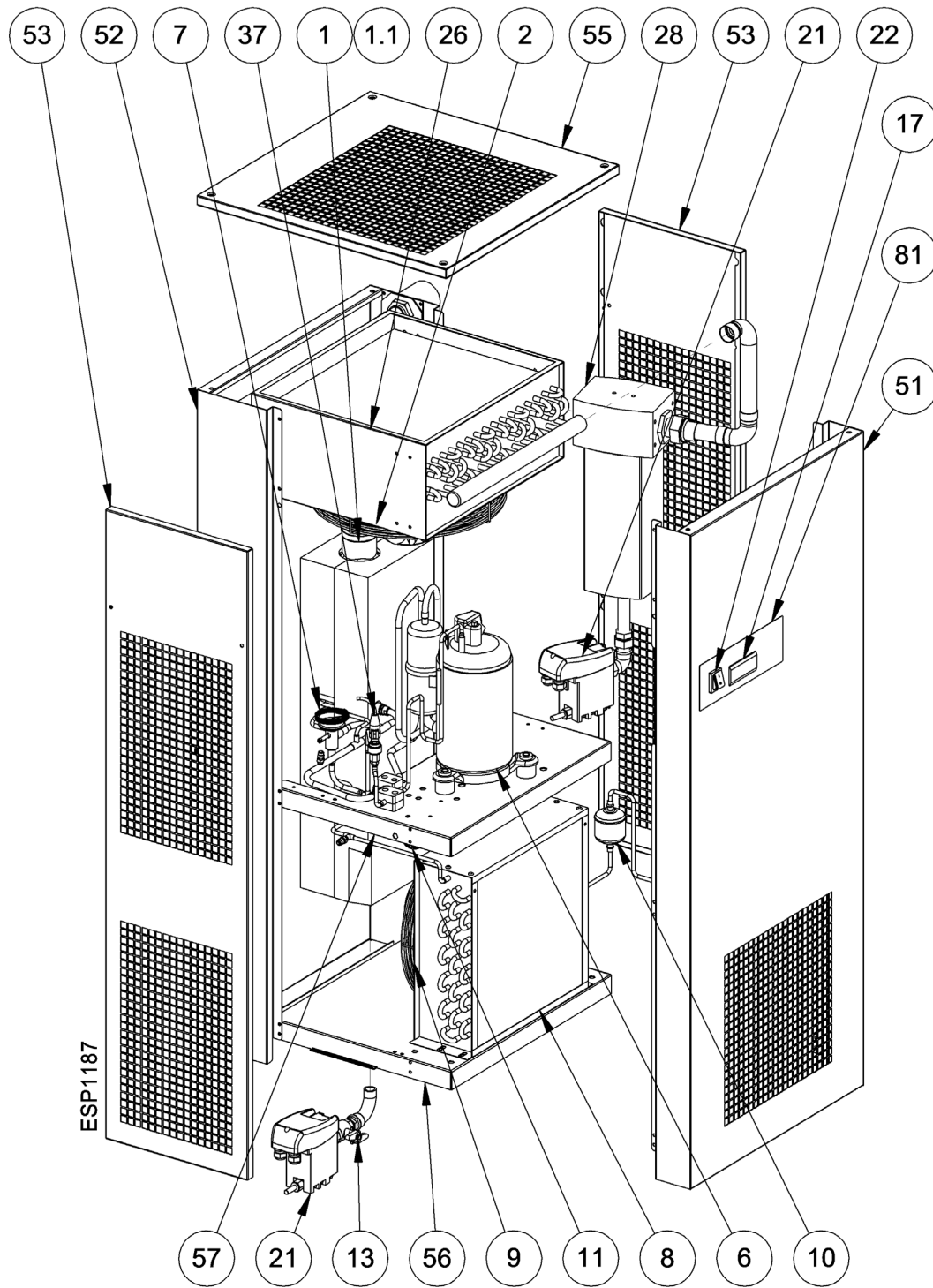

13.2.6 Exploded diagram SPRHT 250T-300T

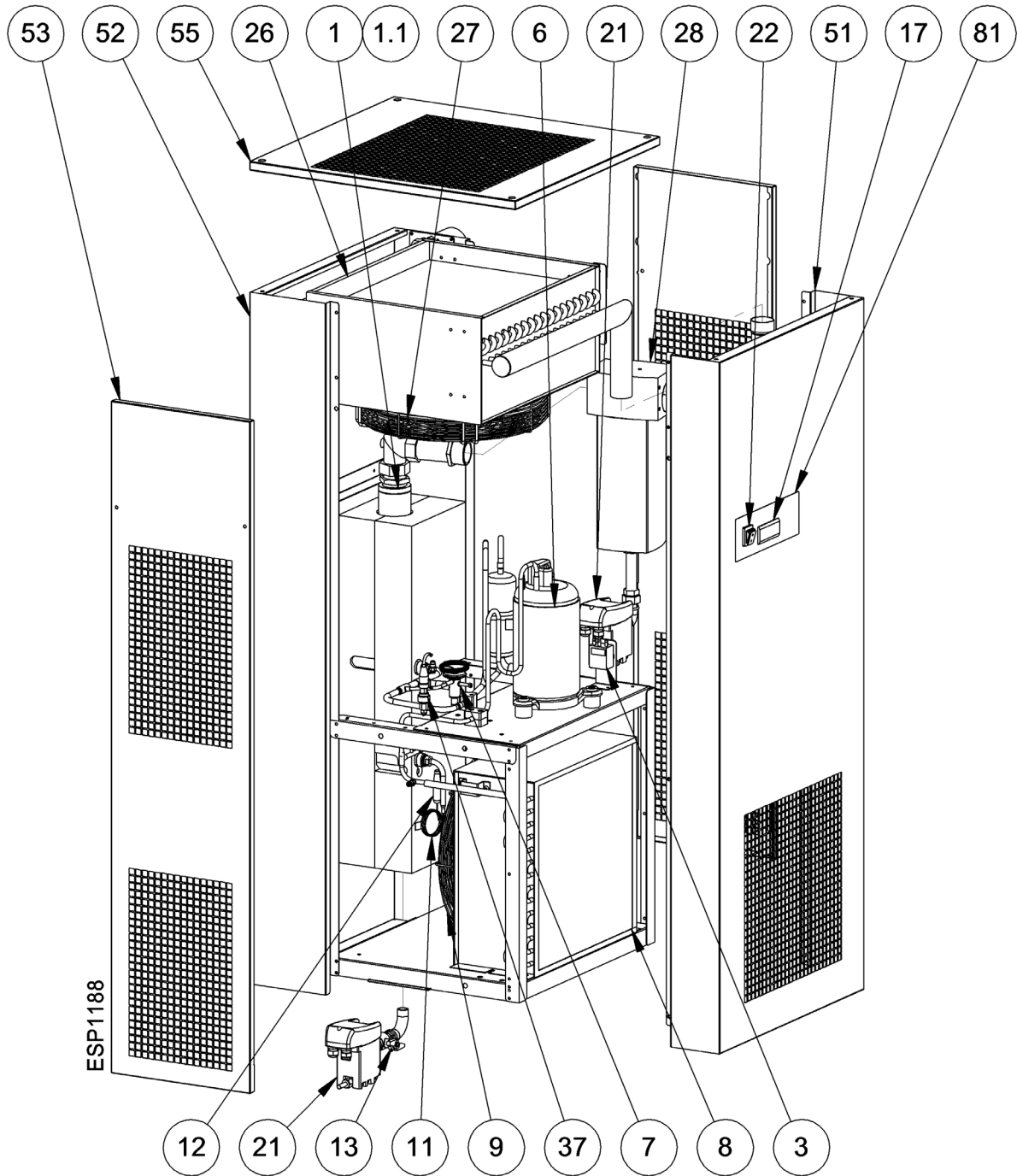

13.2.7 Exploded diagram SPRHT 350T

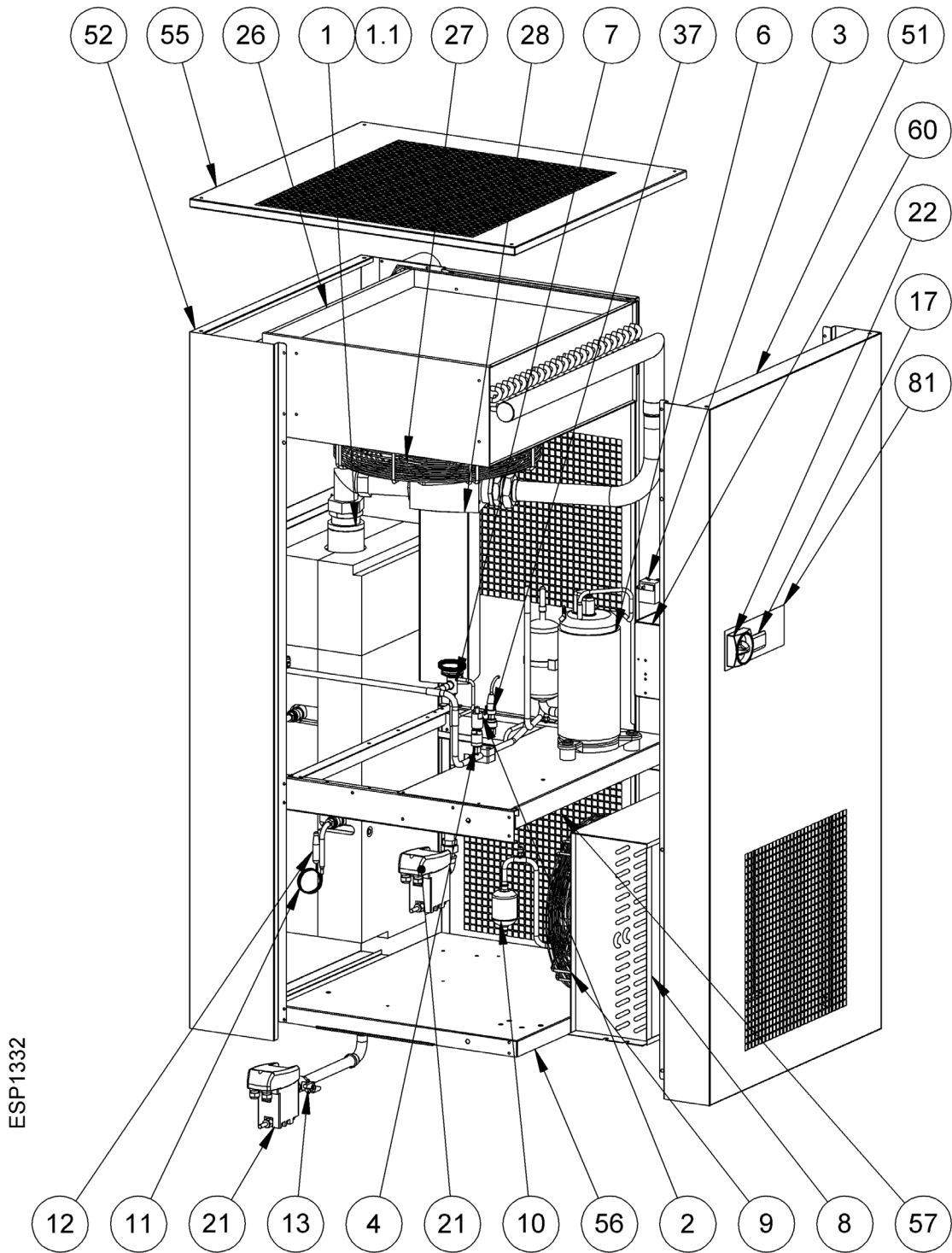

13.3 Electric diagrams

13.3.1 Electric diagrams – list of components

- MC** : Compressor
- MV1** : Condenser fan
- MV2** : Aftercooler fan
- DMC34** : DMC34 electronic instrument – air dryer control
- BT1** : Temperature probe – Dew Point
- HPS** : Pressure switch – compressor discharge side (HIGH PRESSURE)
- LPS** : Pressure switch – compressor suction side (LOW PRESSURE)
- BP2** : Pressure transducer
- TS** : Safety temperature switch
- TSA** : Aftercooler safety thermo switch
- ELD** : ZL Drain
- EVD** : Timed condensate drain
- S1** : ON/OFF switch
- KC1** : TS Power contactor

- NT1** : Only air-cooled
- NT2** : Check the transformer connections with regard to the supply voltage
- NT3** : Jump, if not installed
- NT4** : Provided and cabled by the customer
- NT5** : Internal control
- NT6** : Time-controlled drain outlet (not used)
- NT7** : Only water-cooled

- | | | | | | |
|-----------|---|--------------|--------------|---|-------------|
| BN | = | BROWN | OR | = | ORANGE |
| BU | = | BLUE | RD | = | RED |
| BK | = | BLACK | WH | = | WHITE |
| YG | = | YELLOW/GREEN | WH/BK | = | WHITE/BLACK |

13.3.2 Electric diagram SPRHT 20T-50T

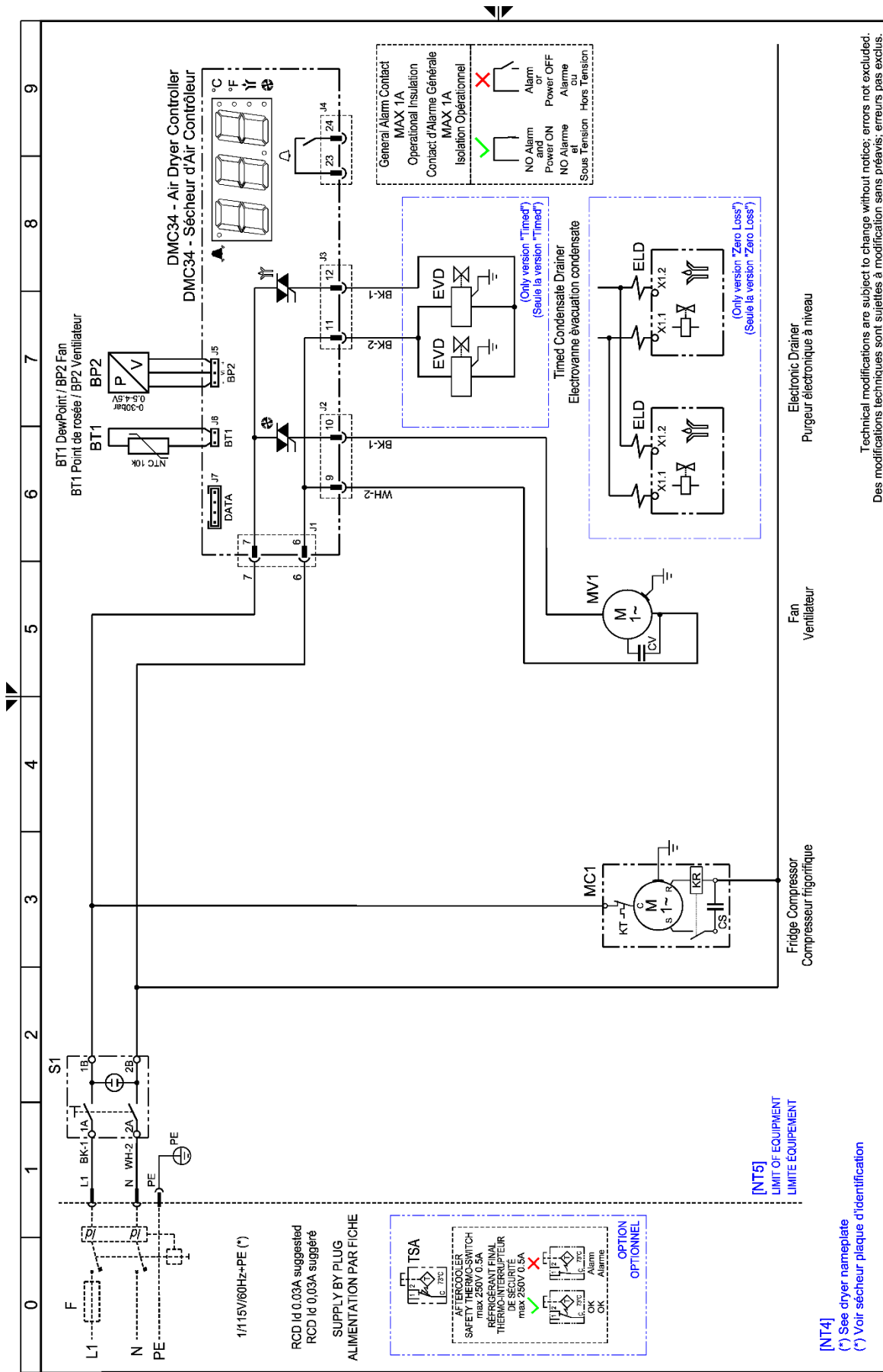

[NT4] (*) See dryer nameplate
 (*) Voir sécheur plaque d'identification

Technical modifications are subject to change without notice; errors not excluded.
 Des modifications techniques sont sujettes à modification sans préavis, erreurs pas exclus.

13.3.3 Electric diagram SPRHT 75T-100T

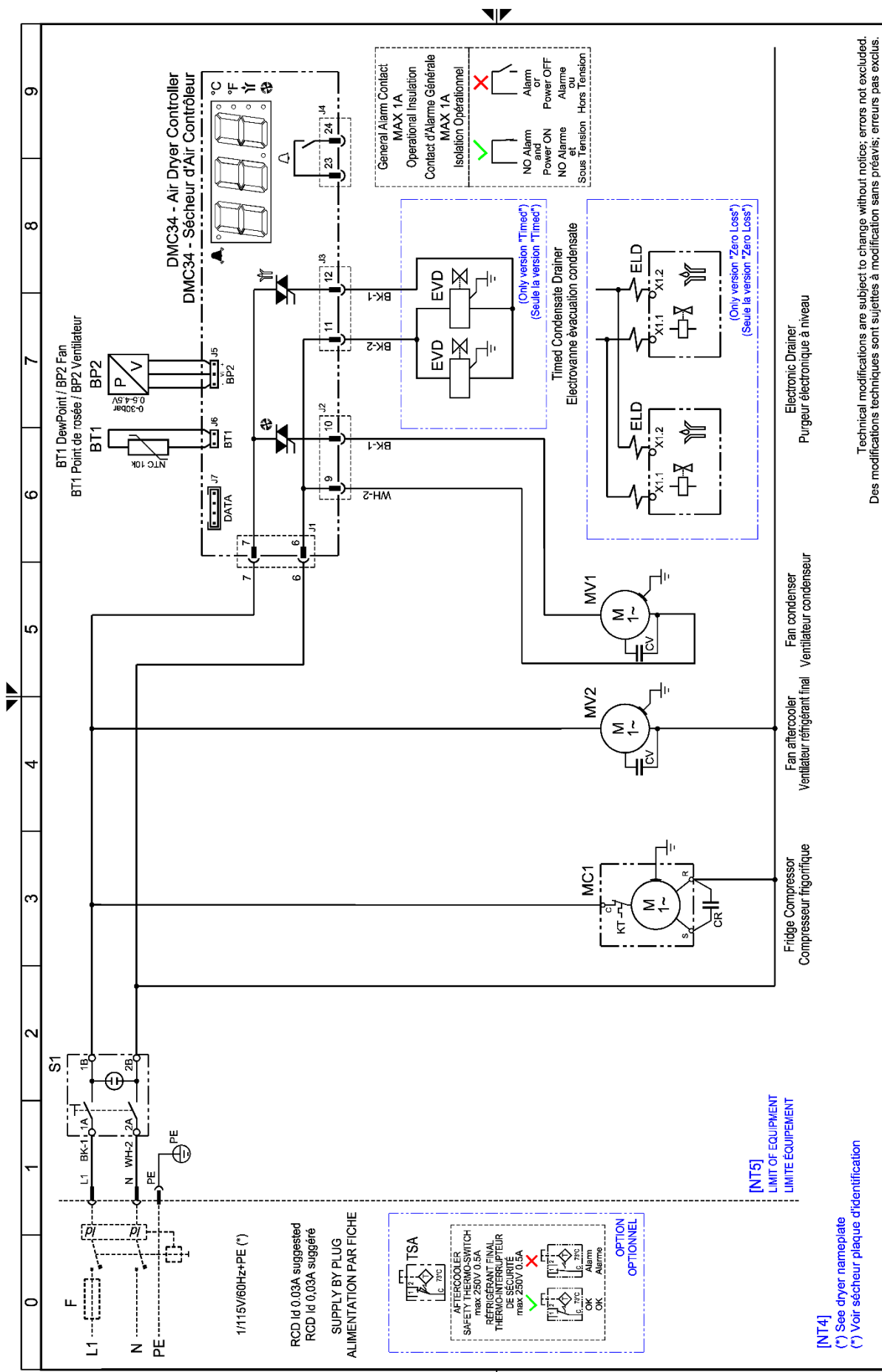

Technical modifications are subject to change without notice; errors not excluded.
Des modifications techniques sont sujettes à modification sans préavis; erreurs pas exclus.

Rev. / Rév.

00

WU012_V00

Notes / Remarque:

Sheet / feuille 01 of / de 01

13.3.4 Electric diagram SPRHT 150T

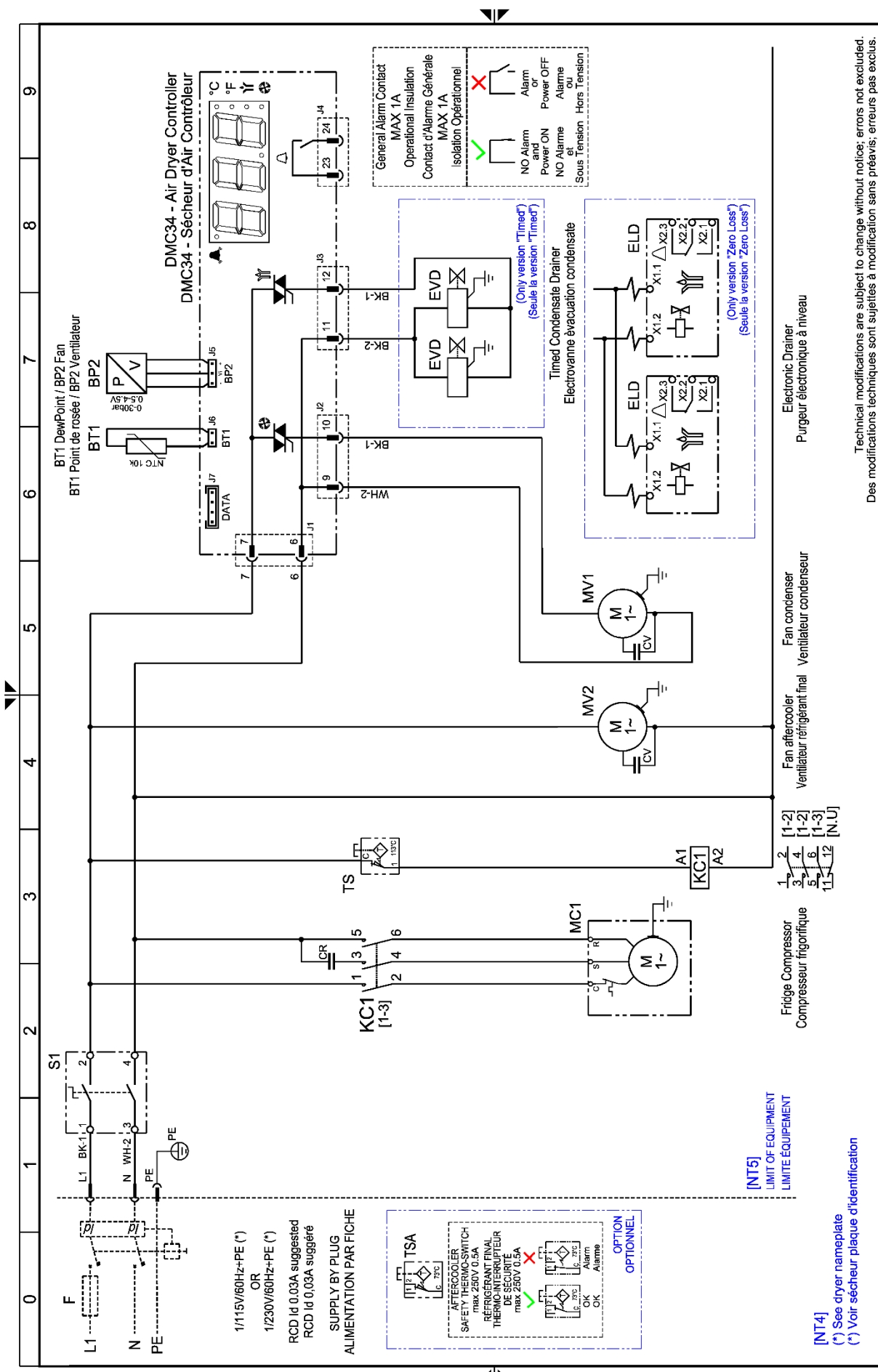

Technical modifications are subject to change without notice; errors not excluded.
 Des modifications techniques sont sujettes à modification sans préavis; erreurs pas exclus.

Drawing no. / Numéro de dessin : **WU013_V00**
 Rev. / Rév. : **00**
 Notes / Remarques :

13.3.5 Electric diagram SPRHT 200T-250T

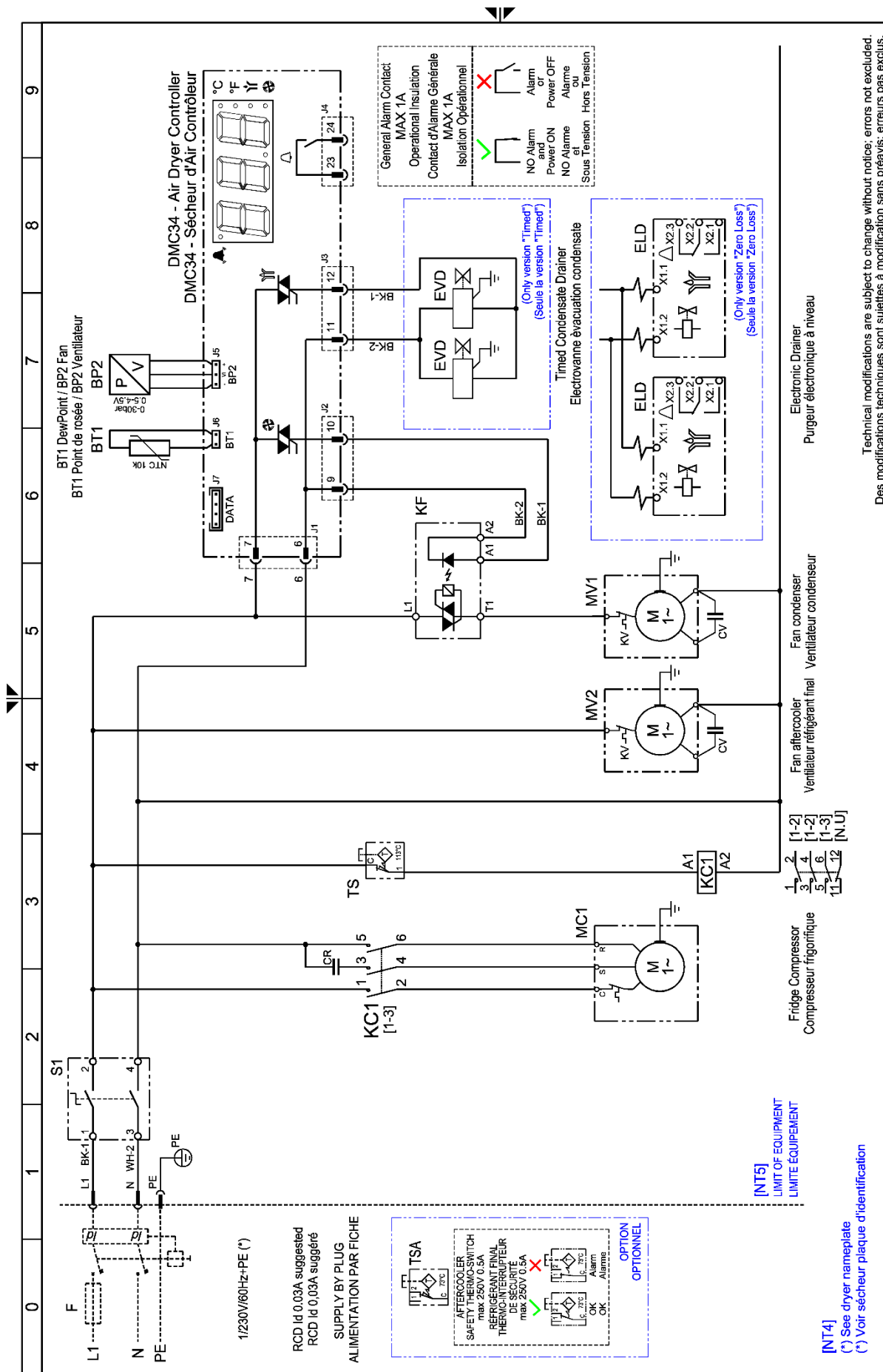

Technical modifications are subject to change without notice; errors not excluded.
Des modifications techniques sont sujettes à modification sans préavis; erreurs pas exclus.

Rev. / Rév.

00

WU014_V00

Notes / Remarque:

Sheet / feuille 01 of / de 01

13.3.6 Electric diagram SPRHT 300T-350T

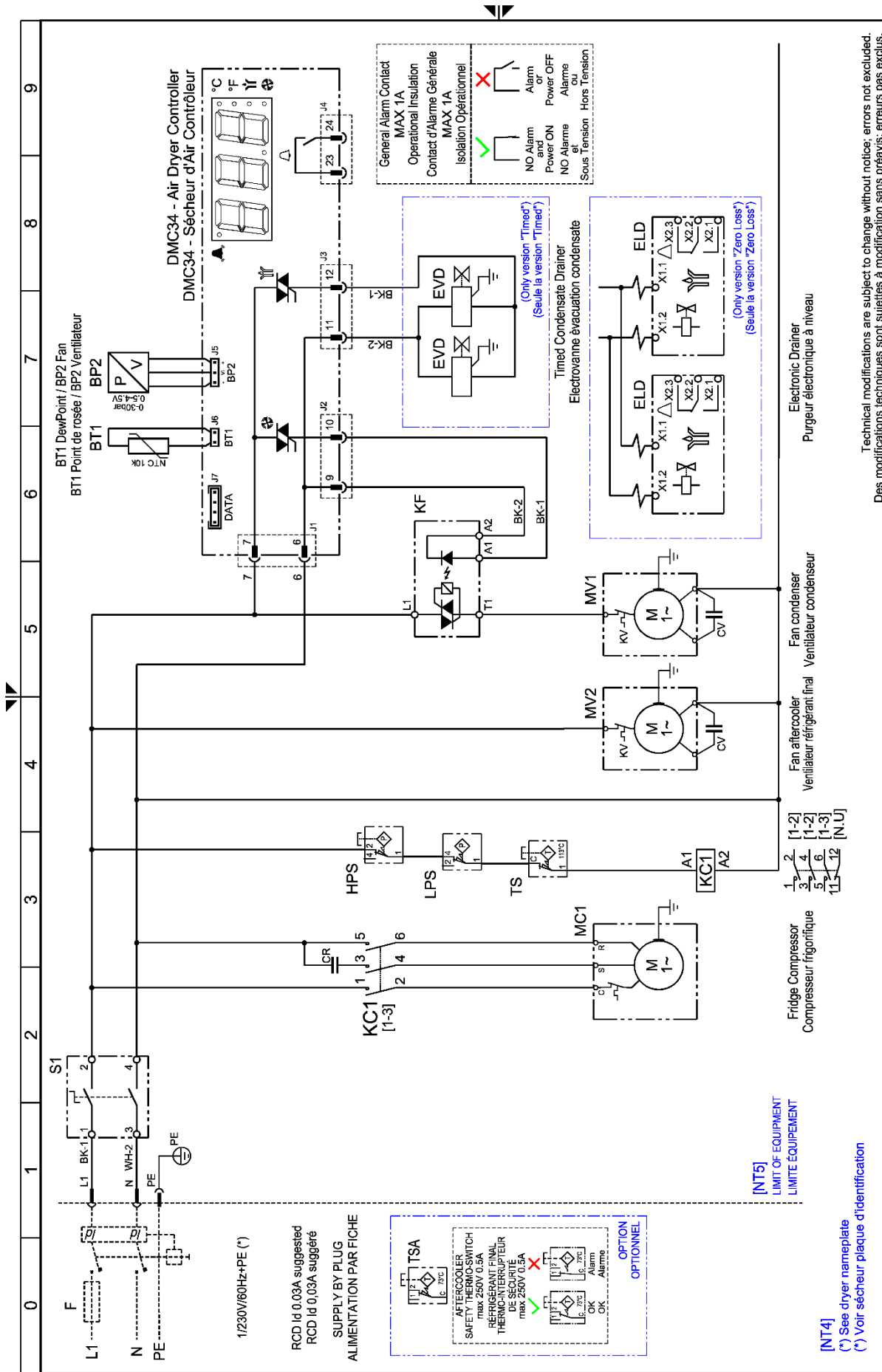

Technical modifications are subject to change without notice, errors not excluded.
Des modifications techniques sont sujettes à modification sans préavis, erreurs pas exclus.

Drawing no. / Numéro de dessin : WU015_V00

Notes / Remarque:

Rev. / Rév. 00

Sheet / feuille 01 of / de 01

Original operating instructions in English.
Subject to technical changes / errors excepted.

 Control Nr. 4009404
Conforms to ANSI/UL Std. 1995
Cert. to CSA-C22.2 No.236

SPRHT_20T_350T_manual_en_04_2021

74MD0029A9-EN_01
