

ENHANCING AIR QUALITY AND EQUIPMENT LONGEVITY



Compressed air quality plays a crucial role in ensuring efficiency, equipment longevity, and overall operational success in the demanding world of construction, mining, and industrial applications. Sullivan-Palatek diesel air compressors equipped with aftercoolers and advanced filtration systems provide a superior solution to combat moisture and contaminants in compressed air, optimizing both performance and durability.



WHAT IS AN AFTERCOOLER?

An aftercooler is a critical component in diesel-powered air compressors designed to reduce the temperature of compressed air before it enters downstream applications. As air is compressed, its temperature increases, causing moisture to remain in a vapor state. By cooling the air, an aftercooler condenses this moisture, allowing it to be effectively removed from the system.

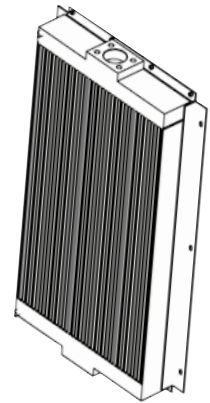

BENEFITS OF AN AFTERCOOLER IN DIESEL AIR COMPRESSORS

REDUCED MOISTURE CONTENT

Lowers the risk of water vapor condensing in air lines, preventing corrosion and damage to pneumatic tools.

PREPARES AIR FOR FILTRATION

Ensures that water and contaminants are more easily captured by filtration units.

IMPROVED AIR QUALITY

Helps meet industry standards for dry, clean compressed air.

EQUIPMENT PROTECTION

Reduces the likelihood of clogged hoses, valves, and air tools.

ENERGY EFFICIENCY

Cooler air increases efficiency by reducing the workload on downstream dryers and filters.

WHY FILTRATION MATTERS

Filtration is essential to remove particulate matter, oil aerosols, and residual moisture from compressed air. Without proper filtration, contaminants can degrade tools, clog pipelines, and lead to costly downtime. Sullivan-Palatek compressors integrate high-performance filtration systems that work seamlessly with aftercoolers to deliver clean, dry air for various applications.

KEY ADVANTAGES OF FILTRATION ON DIESEL COMPRESSORS

EXTENDED EQUIPMENT LIFE

Prevents damage to air tools and machinery by removing harmful contaminants.

REDUCED MAINTENANCE COSTS

Minimizes the need for frequent cleaning and part replacements.

CONSISTENT AIR QUALITY

Meets ISO 8573-1 air purity standards for critical applications.

INCREASED PRODUCTIVITY

Ensures optimal performance in demanding environments such as construction sites, sandblasting operations, and painting applications.

SULLIVAN-PALATEK: A LEADER IN AFTERCOOLED & FILTERED AIR SOLUTIONS

Sullivan-Palatek diesel air compressors are engineered to deliver premium compressed air solutions with built-in aftercoolers and filtration options. Our advanced designs help operators achieve maximum efficiency while protecting their investment from the damaging effects of moisture and contaminants.

By incorporating aftercoolers and filtration into your air compressor system, you ensure consistent performance, reduced maintenance downtime, and long-term cost savings. Choose Sullivan-Palatek for reliable, high-quality compressed air solutions that keep your operations running smoothly.

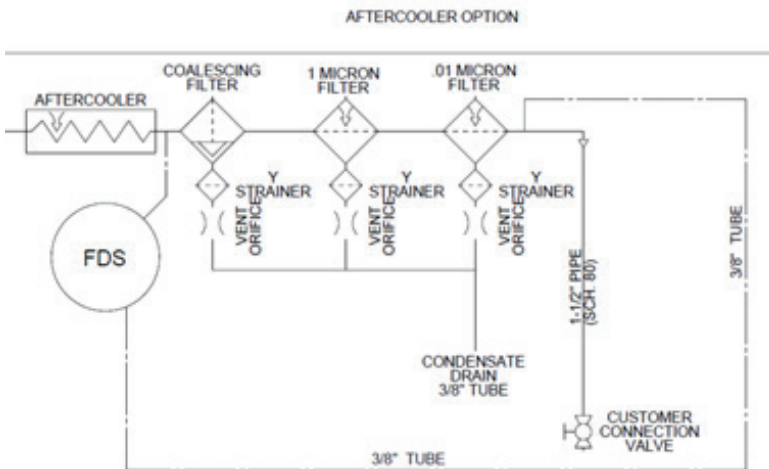

Aftercooler	Design Inlet Temperature	250°F
	Approach	15°F
	Maximum Inlet Pressure	200 PSIG
Separator	Maximum Inlet Pressure	232 PSIG
	Maximum Inlet Temp	140°F
	Drain Type	Internal Float
Particulate	Rating:	Removes Solid Particles 1 microns and Larger
	Efficiency:	99.9% Efficient
	Configuration:	Inline, T-Type
	Differential Pressure	0.73 PSID
	Indication:	Differential Pressure Gauge
	Drain:	Internal Automatic Float
	Housing Rating	232 PSIG @ 140°F
Coalescer	Rating:	Removes Solid Particles 0.01 microns and Larger
	Efficiency:	99.9% Efficient
	Max. Oil Carryover:	0.01 mg/m ³
	Configuration:	Inline, T-Type
	Differential Pressure (Wet)	1.7 PSID
	Indication:	Differential Pressure Gauge
	Drain:	Internal Automatic Float
Housing Rating	232 PSIG @ 140°F	

CONTACT US

For more information on how Sullivan-Palatek's diesel air compressors with aftercoolers and filtration can benefit your operations, contact our team today

219.874.2497 |

SULLIVAN-PALATEK.COM |

INFO@PALATEK.COM