

OPERATION & SERVICE MANUAL

WHEEL-MOUNTED PORTABLE COMPRESSOR \ 185 CFM



D185PIZP

ISUZU ENGINE
TIER 4 FINAL

DOCUMENT INFORMATION

© Sullivan-Palatek, Inc.
ALL RIGHTS RESERVED

Part Number: 05018730-0315
Revision: 00

CONTACT INFORMATION

Sullivan-Palatek, Inc.
1201 West US Highway 20
Michigan City, Indiana 46360
Phone: (219) 874-2497
Fax: (219) 872-5043
Toll Free: (800) 438-6203
Website: www.sullivan-palatek.com

RECORD KEEPING

Record the model and serial number of the compressor for future reference when contacting the factory for service or parts.

Model Number: _____

Serial Number: _____

DISCLAIMER

Although this manual is checked for conformity with the machines described, we cannot guarantee that all errors will be excluded. Necessary corrections will be made in future editions of this manual. This manual is subject to change without notice.

REVISION HISTORY

#	DATE	SECTION(S)	DESCRIPTION
00	2023-08		Released for publication

CONTENTS

I	WARRANTY	I
II	ABOUT THIS MANUAL	III
II.1	Safety Instructions	iii
II.2	Manual Organization	iii
II.3	Supplemental Documents	iii
1	SAFETY	1
1.1	General Safety	2
1.2	Pressure Release	2
1.3	Fires and Explosion	2
1.4	Moving Parts	3
1.5	Toxic and Irritating Substances	4
1.6	Hot Surfaces, Sharp Edges, Sharp Corners and Vacuum	4
1.7	Electrical Shock	4
1.8	Entrapment	4
2	TRANSPORTING AND LOCATING	5
2.1	Receiving	6
2.2	Lifting	6
2.3	Drawbars and Brake Actuators	6
2.4	Preparing to Tow	7
2.5	Towing	7
2.6	Parking or Locating Compressor	8
3	OPERATION	9
3.1	General Operating Safety	10
3.2	Preparing for Initial Start-Up	10
3.3	Normal Starting	10
3.4	Normal Stopping	11
3.5	Sullivan-Palatek Electronic Controller (SPEC) Operational Instructions	11
3.6	Operating Under Extreme Conditions	13
3.7	Pneumatic Tools Application	13
3.8	Jump-Starting Battery	14
4	COMPONENT DESCRIPTION	17
4.1	Portable Compressor Package	18
4.2	Engine	18
4.3	Air End Assembly	18
4.4	Discharge System	18
4.5	Lubrication System	19
4.6	Capacity Control System	20
4.7	Noise Control Systems	20
4.8	Electrical and Protective Circuit System	21
4.9	Engine Shutdown Protection	21
4.10	Instrument Panel	22

5	MAINTENANCE	25
5.1	Maintenance Schedule	26
5.2	Bolt Torque Guidelines	27
5.3	Compressor Lubrication	27
5.4	WEATHER-ALL™ Compressor Lubricant	28
5.5	Oil Sample for Analysis	29
5.6	Air Intake Filter	30
5.7	Compressor Oil Filter	30
5.8	Compressor Shaft Oil Seal	30
5.9	Oil Return Line	30
5.10	Air/Oil Separator	31
5.11	Thermal Valve	31
5.12	Oil Cooler	31
5.13	Grease	31
5.14	Engine Lubrication	31
5.15	Control Adjustments	32
2.18	Recommended Spare Parts	33
2.19	Service Kits	33
5.16	Recommended Spare Parts	34
5.17	Service Kits	34
6	TROUBLESHOOTING	35
6.1	Introduction	36
6.2	Unplanned Shutdown	36
6.3	Discharge Pressure Is Too Low	36
6.4	Discharge Pressure is Too High or Relief Valve Blows	37
6.5	Relief Valve Blows with Throttle Lever in Idle Position	37
6.6	Pressure Does Not Blow Down After Shutdown	37
6.7	Compressor Oil Level is Decreasing Excessively	37
6.8	Oil in Service Line	37
6.9	Engine Does Not Accelerate Or Will Not Maintain Full Load Speed	38
6.10	Separator Plugging	38
6.11	Engine Speed Control Does Not Change to Idle Speed with Service Valves Closed	38
6.12	Engine Speed Control Does Not Change to Full Speed with Air Demand	38
6.13	Compressor Oil Leaking in Control Lines/Orifices	39

WARRANTY

Sullivan-Palatek Portable Air Compressor STANDARD WARRANTY

Sullivan-Palatek warrants its new portable air compressor products to be free from defects in material and workmanship, subject to the following provisions:

Warranty Registration: To validate the warranty for each product the purchaser shall complete and return the Warranty Registration Form within 30 days of delivery to the first user or rental.

Warranty Period: The warranty period for applicable Sullivan-Palatek products is as follows (subject to the Exclusions and Limitations noted below):

Air ends on new machines – stator and rotor assembly: **Single stage** compressor models: the first to expire; 42 months from shipment by Sullivan-Palatek or 36 months from delivery to the first user. **Two stage high pressure** compressor models: the first to expire; 30 months from shipment by Sullivan-Palatek or 24 months from delivery to the first user.

Remainder of new portable air compressor machines: the first to expire; 18 months from shipment by Sullivan-Palatek or 12 months from delivery to the first user.

Parts, accessories and attachments sold separately from machines, excluding warranty replacement parts and hand tools: the first to expire; 6 months from shipment by Sullivan-Palatek or 3 months from delivery to the first user.

Warranty replacement parts: remainder of the original warranty period of the replaced part.

Sullivan-Palatek's Obligations: Sullivan-Palatek's exclusive obligations under its warranty are (i) to repair or replace any defective part at Sullivan-Palatek's option and subject to return of defective parts, (ii) to pay the reasonable cost of making the repair or reinstalling the replacement part, and (iii) for air compressors having two or more axles, reimbursement of up to four hours travel labor and up to 200 miles (100 miles travel radius) per event to make repairs. Reimbursement rates for travel and mileage are set at the discretion of Sullivan-Palatek and are subject to change without notice.

Purchaser's Responsibility: Purchaser shall (i) give Sullivan-Palatek written notice of any warrantable failure of any Sullivan-Palatek product within the applicable warranty period, (ii) make the product available for repair at a Sullivan-Palatek authorized repair facility, (iii) pay reasonable travel expenses for field repairs performed at purchaser's request, and (iv) pay the costs of investigating performance complaints that are not covered by this warranty.

Exclusions and Limitations: Air end seals are not warranted. Engines, tires and batteries are not warranted by Sullivan-Palatek but are warranted only by the manufacturers of these components. Sullivan-Palatek has no obligation for product failures or defects resulting from overloading, misuse, neglect, accident, failure to comply with Sullivan-Palatek's product manual, or failure to install product improvements provided by Sullivan-Palatek. Use of attachments, accessories or service parts not supplied or recommended by Sullivan-Palatek may void the warranty of that product.

THIS WARRANTY IS SULLIVAN-PALATEK'S ONLY WARRANTY OF ITS PORTABLE AIR COMPRESSOR PRODUCTS AND IS IN LIEU OF ANY OTHER WARRANTIES, EXPRESS OR IMPLIED. ANY IMPLIED WARRANTIES OF MERCHANTABILITY OR OF FITNESS FOR A PARTICULAR PURPOSE ARE EXCLUDED. SULLIVAN-PALATEK HAS NO OBLIGATION UNDER THIS WARRANTY OR OTHERWISE (REGARDLESS OF THE FORM OF ACTION) FOR SPECIAL, CONSEQUENTIAL OR INCIDENTAL DAMAGES, INCLUDING WITHOUT LIMITATION LOST PROFITS OR LOST INCOME. THE TOTAL RESPONSIBILITY OF SULLIVAN-PALATEK FOR CLAIMS, LOSSES, LIABILITIES OR DAMAGES, WHETHER IN CONTRACT OR TORT ARISING OUT OF OR RELATED TO ITS PRODUCTS SHALL NOT EXCEED THE PURCHASE PRICE OF THE COVERED PRODUCT.

This warranty applies to all Sullivan-Palatek portable air compressors shipped after November 1, 2015 unless expressly superseded by a later warranty. In the event of any conflict between this warranty and earlier warranty statements, the terms of this warranty will apply.

05.31.23



ABOUT THIS MANUAL

II.1 SAFETY INSTRUCTIONS

Instructions for the safe operation and maintenance of the Sullivan-Palatek air compressor are located throughout this manual. These instructions are presented with different labels according to the level of risk involved, described as follows:

WARNING! *Is used when death or personal injury could occur if the instruction is not followed.*

CAUTION! *Is used when damage to property could occur if the instruction is not followed.*

NOTE! *Is used to inform the reader of installation, operation or maintenance information that is important but not hazardous.*

II.2 MANUAL ORGANIZATION

Anyone operating or servicing the Sullivan-Palatek air compressor should read this entire manual and be familiar with its information. The following is a quick guide to the contents in this manual:

SECTION 1: SAFETY

This section contains important basic information regarding general safety precautions for maintaining and operating air compressors.

SECTION 2: TRANSPORTING AND LOCATING

This section contains instructions and safety guidelines for transporting and locating a portable air compressor.

SECTION 3: OPERATION

This section contains an overview of general operating safety, initial start-up procedures, how to start and stop the air compressor, SPEC instructions, in addition to guidelines for operating under extreme conditions and procedures for pneumatic tool applications.

SECTION 4: COMPONENT DESCRIPTION

This section contains information about how the different systems and components function within an air compressor.

SECTION 5: MAINTENANCE

This section contains a maintenance schedule and step-by-step instructions for performing common maintenance procedures. A list of recommended spare parts to keep on hand is also included.

SECTION 6: TROUBLESHOOTING

This section contains symptoms, causes and remedies for common air compressor malfunctions.

II.3 SUPPLEMENTAL DOCUMENTS

For more detailed information on certain components or optional equipment specific to this compressor, supplemental documents are provided, including the and the Parts & Specifications Manual. The Engine manual can be accessed at www.kohlerpower.com.

1 SAFETY

TOPICS IN THIS SECTION:

» General Safety	2
» Pressure Release	2
» Fires and Explosion	2
» Moving Parts	3
» Toxic and Irritating Substances	4
» Hot Surfaces, Sharp Edges, Sharp Corners and Vacuum	4
» Electrical Shock	4
» Entrapment	4

**CALIFORNIA
PROPOSITION 65 WARNING**
Diesel engine exhaust and some of
its constituents are known to the
State of California to cause cancer,
birth defects and other reproductive
harm.

1.1 GENERAL SAFETY

Safety is a prime consideration in the design and manufacture of the compressor components. Ultimately, the responsibility for safe operation rests with the individuals who use and maintain the compressor. The following safety precautions are offered as a guide for the safe operation and maintenance of this machinery:

- » Only trained and authorized personnel who have read and understand this user's manual should operate the air compressor. Failure to follow the instructions, procedures, and safety precautions in the manual will increase the possibility of accidents and injuries.
- » Never start the air compressor unless it is safe to do so. Do not attempt to operate the air compressor with a known unsafe condition. If an unsafe condition exists or maintenance is required, tag the air compressor and render it inoperative by disconnecting the battery so others who may not know of the unsafe condition cannot attempt to operate it until the unsafe condition is corrected.
- » Use and operate the air compressor only in full compliance with all pertinent Federal, State and Local codes or requirements including OSHA, EPA and other relevant agency requirements.
- » Do not modify the compressor or install attachments without consulting the manufacturer.
- » Known and potential hazards associated with the operating and servicing of portable air compressors are detailed in the following pages. Not all hazards can be anticipated and the operator of the equipment is ultimately responsible for identifying hazardous and dangerous conditions, avoiding dangerous operation and preventing accidents.

1.2 PRESSURE RELEASE

- » Remove the pressure from air, oil, and cooling circuits before disconnecting pipes, fittings or related items. Pay attention to the possible residual pressure when you disconnect a device from a pressurized circuit.
- » Do NOT try to detect pressure leaks with your hands. It is not always possible to identify a leak from a tiny hole. Use a piece of paper or wood to locate a suspected leakage. Wear safety glasses when detecting leaks.
- » Oil, fuel, or compressed air can cause injuries. Fluid leaking under pressure has enough force to penetrate under the skin and cause serious bodily injuries.
- » Do not open sump (receiver) oil filler cap when compressor is running and air system is pressurized. Shut down the compressor and bleed the sump (receiver) pressure to zero before removing the oil filler cap.
- » Do not remove cooler cap while the engine is running, or immediately after the engine stops. Wait until the coolant temperature is below its boiling point, then loosen cap slowly to its stop to relieve any excess pressure. Make sure coolant is not boiling before removing cap completely, and protect yourself by wearing safety glasses.

1.3 FIRES AND EXPLOSION

1.3.1 FUEL & LIQUIDS

WARNING! *Fire or explosion can result from spilled fuel, oil and other flammable liquids.*

- » Refuel at a service station or from a fuel tank designed for the purpose. Ground the machine to mobile dispensers prior to refueling. Verify machine is off before refueling.
- » Immediately clean up any spills or leaking fuel, battery electrolyte, oil, or anti-freeze solution.
- » Keep sparks, flames, and other sources of ignition away and do not permit smoking in the vicinity when adding fuel, checking or adding electrolyte to batteries, checking or adding oil, or when refilling air line anti-icing systems with anti-freeze.
- » Replace damaged fuel tanks or lines. Do not store or attempt to operate the compressor with any known leaks in the fuel system or oil lines.
- » Do not permit liquids to accumulate in bottom of the compressor frame. Prevent contact with acoustical surfaces of the air compressor. Wipe down using an aqueous industrial cleaner or steam clean as required. If necessary, remove acoustical material, clean all surfaces and then replace acoustical material. Do not use flammable solvents for cleaning purposes.

- » Anti-freeze compound used in air line anti-icing systems contains methanol, which is flammable. Use systems and refill with compound only in well-ventilated areas, away from heat, open flames, or sparks. Do not expose any part of these systems or the anti-freeze compound to temperatures above 150°F (65°C). Vapors from the anti-freeze compound are heavier than air. Do not store compound or discharge treated air in confined or unventilated area. Do not store containers or anti-freeze compound in direct sunlight.
- » Store flammable liquids in suitable containers and cabinets, away from sources of sparks and heat.

1.3.2 BATTERIES AND WIRING

WARNING!

Fire or explosion can result from electrical arcing from terminal, battery connections and improperly grounded equipment.

- » Do NOT check the battery charge by placing a metal object between the terminals. Use a voltmeter or a hydrometer.
- » Do NOT charge a frozen battery. There is risk of explosion. If the battery is frozen, heat it up to at least 61°F (16°C).
- » Do NOT charge a battery that is in excess of 113°F (45°C).
- » Disconnect the grounded (negative) battery connection prior to attempting any repairs or cleaning inside the enclosure. Tag the ground cable with a warning not to reconnect until servicing is complete.
- » Keep electrical wiring, battery terminals and other terminals in good condition. Replace any wiring that has cracked, cut, abraded, or otherwise degraded insulation. Replace terminals if worn, discolored or corroded. Keep all terminals clean and tight. Turn off battery charger before making or breaking connections to the battery. Wear a face shield whenever servicing or working on the battery.
- » Keep tools and other grounded conductive objects away from exposed live electrical parts to avoid arcing, which might serve as a source of ignition.
- » Always avoid electrical parts when washing the compressor.

1.3.3 COMBUSTIBLES

- » Prior to welding or making weld repairs on the compressor, remove any acoustical material or other material that may be damaged by heat or that may support combustion. Remove and isolate negative battery cable.
- » Do not operate compressor under low overhanging leaves or permit leaves and foliage to contact hot exhaust system surfaces when operating in forested areas.
- » Do not expose dry grass, grass cuttings, oil, or any other flammable material to exhaust gases. Always keep the engine and muffler clean.
- » Keep oily rags, trash, leaves, litter, or other combustibles out of and away from the compressor.
- » Keep a suitable fully charged class BC or ABC fire extinguisher or extinguishers nearby when servicing and operating the compressor.

1.4 MOVING PARTS

- » Make sure all personnel are clear of the compressor prior to starting, operating, or shutting off the compressor.
- » Keep hands, arms, and other parts of the body, as well as clothing, away from belts, pulleys, and other moving parts.
- » Wear snug fitting clothing and confine long hair when working around compressors or any machinery.
- » Avoid slips and falls when working around the compressor. Keep hands, feet, floors, controls, and walking surfaces clean and free of oil, water, anti-freeze, or other liquids to minimize the possibility of slips or falls. Use extreme caution when ground is covered with ice or snow.
- » Do not attempt to operate the compressor with the fan guard or other guards removed. Keep access doors closed except when repairing, adjusting or performing service, or when starting or stopping the compressor.
- » Shut down engine before servicing, especially when adding fuel, oil, coolant, lubricants, airline anti-freeze compound, or battery electrolyte. The engine must also be shut down before making adjustments. Restart engine to check adjustment. If adjustment is incorrect, shut down the engine again, readjust, then restart engine to recheck the adjustment.

1.5 TOXIC AND IRRITATING SUBSTANCES

WARNING! *Do not use air from this compressor for breathing air. Breathing unfiltered air from this compressor can result in serious injury or death.*

NOTE! *Under specific guidelines and in full compliance with OSHA Standards 29 CFR 1920 and any other federal, state, or local codes or regulations compressed air can be used for breathing air. Sullivan-Palatek does not provide equipment and instructions for this application and its products are not produced for this application or use.*

- » Operate the compressor only in open or well-ventilated areas.
- » Carbon monoxide will kill. If the machine is operated indoors, discharge the engine exhaust outdoors and be certain there are no exhaust system leaks that can discharge exhaust within the building.
- » Locate the compressor so that exhaust will not be carried toward personnel, air intakes servicing personnel areas or toward the air intake of any other portable or stationary compressor.
- » Fuel, oil, coolant, lubricant, and battery electrolyte used in the compressor are typical of the industry. Care should be taken to avoid accidental ingestion or skin or eye contact. In the event of ingestion or contact, seek medical treatment promptly. Do not induce vomiting if fuel is ingested. Wash with soap and water in the event of skin contact.
- » Wear an acid-resistant apron and a face shield or goggles when servicing the battery. If electrolyte is spilled on skin or clothing, immediately flush and wash with large quantities of water.
- » Do not use airline anti-icing systems in airlines supplying respirators or other breathing air utilization and equipment, and do not discharge air from these systems in unventilated or other confined areas.
- » Wear goggles or a full face shield when adding anti-freeze compound to air line anti-icing systems. The anti-freeze compound used in airline anti-icing systems contains methanol and is toxic, harmful, or fatal if swallowed. Avoid contact with the skin or eyes and avoid breathing the fumes. If contact with eyes, wash eyes with large quantities of clean water for at least 15 minutes. Medical attention should be obtained immediately. If swallowed, induce vomiting by administering a tablespoon of salt in a glass of clean, warm water until vomit is clear, then administer two teaspoons of baking soda in a glass of clean water. Lay down and cover eyes to exclude light. Seek medical assistance.
- » Do not store airline anti-icing system anti-freeze compound in operator's cabs or in unapproved containers.
- » Do not mix different types of antifreeze. The mixture may cause a chemical reaction and release harmful substances.

1.6 HOT SURFACES, SHARP EDGES, SHARP CORNERS AND VACUUM

- » Avoid contact with hot oil, hot coolant, hot surfaces, and sharp edges and corners.
- » Keep all parts of the body away from all points of air discharge and away from hot exhaust gases.
- » Wear personal protective equipment, including gloves, safety glasses and head covering when working in, on, or around the compressor.
- » Keep a first aid kit available. Seek medical assistance promptly in case of injury. Do not ignore small cuts and burns—these may lead to infection.
- » Keep all loose clothing and parts of the body away from engine and/or compressor intakes or air filter intakes.

1.7 ELECTRICAL SHOCK

- » Keep the towing vehicle or equipment carrier, compressor hoses, tools, and all personnel at least 10 feet from power lines and buried cables. Greater separation from power lines may be prudent when working around high voltage. Contact the utility company for guidance.
- » Keep all parts of the body, any hand-held tools, or other conductive objects away from exposed live parts of the compressor electrical system. Maintain dry footing, stand on insulating surfaces and do not contact any other portion of the compressor when making adjustments or repairs to exposed live parts of the electrical system.

1.8 ENTRAPMENT

- » Make sure all personnel are out of compressor before closing and latching enclosure doors. Larger compressors can hold a man. If it is necessary to enter the enclosure to perform service or adjustments, secure the access door in the open position to avoid the possibility of others closing and latching the door and inform personnel before entering the enclosure.

2 TRANSPORTING AND LOCATING

TOPICS IN THIS SECTION:

» Receiving	6
» Lifting	6
» Drawbars and Brake Actuators	6
» Preparing to Tow	7
» Towing	7
» Parking or Locating Compressor	8

2.1 RECEIVING

Each compressor is operated and tested at the factory before shipment. This testing assures that the unit is operating properly and that the compressor will deliver its rated capacity. Regardless of the care taken at the factory, there is a possibility that adjustments may be altered or damage may occur during shipment. For this reason it is recommended that the unit be checked for proper operation and carefully inspected before it is put in service. The machine should be observed for any possible malfunction during the first few hours of operation.

NOTE!

Satisfactory performance of the compressor depends upon the operator's knowledge of the controls, instruments, and recommended operating procedures. Consequently, the preceding sections of this manual and also the entire Engine Operator's Manual, located at www.kohlerpower.com, should be read and understood before attempting to start and operate this machine.

2.2 LIFTING

- » Properly drain and dispose of any fluids in the containment frame before lifting.
- » This compressor is provided with a lifting bail for routine lifting and loading onto trucks, oil platforms, or similar equipment. It is not intended for extended airlift such as via helicopter.
- » Prior to lifting inspect the lifting bail and points of attachment for the following: cracked welds; cracked, bent, corroded or degraded members; loose bolts or nuts. **Do not lift machine if any of these items are found to be defective.**
- » Make sure entire lifting, rigging, and supporting structure is in good condition and has a rated capacity of at least the net weight of the compressor plus an additional 10% allowance for the weight of snow, ice, mud, or stored tools and equipment. If you are unsure of the weight, then weigh the compressor before lifting.
- » Make sure lifting hook has a functional safety latch, or equivalent, and is fully engaged before lifting compressor from the ground.
- » Support the compressor by using slings under the main frame with appropriate spreader bars when airlifting the machine. Lift only in full compliance with OSHA Standards 29 CFR 1910 subpart N, and other applicable regulations.
- » Do not attempt to lift in high winds.
- » Keep all personnel out from under and away from the compressor when suspended.
- » Lift compressor slowly and smoothly, without jerking. Tilting movements must be limited and rotation must be prevented.
- » Lift compressor no higher than necessary, use guidelines and have spotters properly located.
- » Do not leave suspended compressor unattended.
- » Set compressor down only on level surfaces capable of supporting at least its net weight plus an additional 10% allowance for the weight of snow, ice, mud, or stored tools and equipment.
- » If the compressor is provided with parking brakes, make sure they are set; and always block or chock both sides of all running wheels plus drawbar stabilizer leg before disengaging the lifting hook.

2.3 DRAWBARS AND BRAKE ACTUATORS

WARNING!

Proper alignment and installation of mounting hardware is essential when installing the drawbars and actuators. Check nut threads and start attachment bolt by hand to prevent cross-threading. Failure to comply with this warning may cause property damage and serious bodily harm or death. Maintain torque within recommended ranges.

2.3.1 RECOMMENDED TORQUE RANGES FOR DRAWBARS AND ACTUATORS

APPLICATION	SAE GRADE SCREW	TORQUE (LB-FT) DRY	TORQUE (LB-FT) LUBE
DRAWBAR	5/8 UNC G8	225	175
DRAWBAR	3/4 UNC G8	400	315
DRAWBAR	7/8 UNC G8	640	510
DRAWBAR	1 UNC G8	960	760
ACTUATOR ASSEMBLY (optional)	7/8 UNC G5	455	360

2.4

PREPARING TO TOW

- » Properly drain and dispose of any fluids in the containment frame before towing.
- » Before beginning to tow the compressor, test brake operation, including breakaway switch operation if provided or if equipped.
- » Damaged or worn towing components can result in separation of the compressor from the towing vehicle during towing. Inspect all towing components of both the compressor and towing vehicle for cracks, excessive wear or damage. Check for loose or damaged bolts, nuts or other fasteners. Replace or repair any damaged or worn parts before towing the compressor.
- » The towing vehicle and its coupling device and points of attachment must be rated for towing the wet weight of the air compressor and the weight of stored tools, hose and other equipment plus parasitic accumulation such as mud, snow and ice.
- » Always back the towing vehicle to the compressor and position it for coupling the compressor.
- » The coupling device must be fully engaged, closed, locked and the safety latches engaged.
- » Use a lifting device such as a jack or chain hoist to lift or lower unit to avoid injury to yourself or others. Do not attempt to raise or lower drawbar by hand if the weight is more than can be safely handled.
- » Avoid pinch and crushing injury. Keep hands and fingers clear of the coupling device and all other pinch points. Keep feet clear of drawbar in case it should slip.
- » The towing restraint chains must be attached to the tow vehicle to support the drawbar in the event of accidental uncoupling. Cross chains under front of drawbar before passing them through points of attachment on towing vehicle. Pass each towing restraint chain through its point of attachment on the towing vehicle. Hook each chain to by passing the grab hook over, not through, a link.
- » The coupling device must be free to move throughout the full range of travel while towing. Verify that other components, wires, chains and vehicle attachments do not interfere with or restrict motion of any part of the compressor.
- » Make sure chain length, and if provided, brake and electrical interconnections have sufficient slack to prevent strain when turning and maneuvering. All chains and connections must be supported so they cannot drag or rub on road, terrain, or towing vehicle surfaces. Dragging or rubbing of this equipment will cause wear resulting in damage, and render this equipment inoperative.
- » Fully retract front stabilizer screw jack. If a retractable caster wheel is provided, pull the lock pin, raise and fold the caster wheel, then make sure pin is re-engaged to secure caster wheel in full up and locked position with the wheel horizontal.
- » All stabilizer jacks should be folded to prevent dragging. Use the supplied lock pin for this purpose.
- » Tires must be in good condition, the correct size and load range, and be inflated to the specified pressures. Do not change tire size or type.
- » Wheel lug nuts must be tightened to the specified torque.
- » If provided, make sure all stop, tail, directional, and clearance lights are operating properly and that lenses are clean and unbroken. Ensure that all reflectors and reflecting surfaces on the compressor are clean and functional.
- » Make sure air delivery hoses are disconnected or fully retracted and secured on hose reels, if provided.
- » Make sure all access doors and toolbox covers are closed and latched. If the compressor is large enough to hold a man, make sure all personnel are out before closing and latching access doors.
- » Make sure parking brakes on towing vehicle are set and that wheels are chocked or blocked before releasing the compressor parking brakes, if provided.

2.5

TOWING

WARNING!

Maintain proper torque on wheel lug nuts:

SINGLE AXLE: 85 to 95 LB-FT

TWO AND THREE AXLE: 65 to 75 LB-FT

Failure to maintain lug tightness may result in a wheel loosening and leaving the compressor and causing injury or death or property damage.

- » Non-braked compressors must be towed by a vehicle having a net weight at least 2 times higher than the total weight of the towed compressor ready for use.

- » Observe and follow all local, state, and federal traffic laws. Note and adhere to speed limits and minimum highway speed.
- » Do not exceed maximum towing speeds. Reduce speed accordingly, as dictated by posted signs, weather, road, or terrain conditions.
- » Remember that portable air compressors may approach or exceed the weight of the towing vehicle. Maintain increased stopping distance accordingly.
- » Grades in excess of 15° (27%) or any grade that would over-extend the towing or braking ability of the towing vehicle should be avoided.
- » When towing the compressor, avoid potholes, rocks, rough terrain, obstructions and soft shoulders. Damage to the undercarriage and suspension can result.
- » Do not permit any person to ride in or on the compressor while being towed. Serious injury can result.
- » Make sure the area behind and under the compressor is clear of all persons, animals and obstructions prior to backing.
- » Do not permit anyone to stand or ride on the drawbar, or to stand or walk between the compressor and the towing vehicle. Serious injury or death can result.

2.5.1 MAXIMUM RECOMMENDED TOWING SPEED ON SMOOTH, DRY ROADS

Single and two axle compressors: 55mph (89kmh)

WARNING!

Failure to comply with maximum towing speed may cause property damage and serious bodily injury or death.

2.6 PARKING OR LOCATING COMPRESSOR

- » Park or locate compressor on level ground or across grade.
- » Make sure compressor is parked or located on a firm surface that can support its weight.
- » Park or locate compressor to cause the prevailing wind to direct the exhaust fumes and radiator heat away from the compressor air inlet openings and to prevent ingestion of dust and debris from the work site.
- » Set parking brakes and disconnect breakaway switch cable and all other interconnecting electrical and brake connections, if provided.
- » Block or chock both sides of all wheels.
- » Block or chock both sides of drawbar stabilizer leg or jack.
- » Unhook chains and remove them from the points of attachment on the towing vehicle, then hook chains to each other on drawbar or wrap chains around the drawbar in order to keep them off the ground.
- » If provided, lower front screw jack and rear stabilizer legs. Make sure the ground is firm and capable of supporting the weight of the compressor.
- » If the compressor is provided with a swivel caster wheel, pull pin and lower caster wheel, then make sure pin is re-engaged to secure caster wheel in the full-down and locked position.
- » Disconnect coupling device, keeping hands and fingers clear of all pinch points. Do not attempt to lift the drawbar of portable compressors by hand if the weight is more than you can safely handle - usually weights in excess of 50 pounds. Use a lifting device such as a jack or chain hoist to lift the drawbar to avoid injury to yourself or others.
- » Keep feet clear of drawbar at all times to avoid crushing accidents in case it should slip from your hands or otherwise fall to the ground.
- » All compressor jacks should be lowered and locked.

NOTE!

These guidelines also apply for locating and securing non-towed compressors (skid mounted and utility models). Reference to towing may not apply.

3 OPERATION

TOPICS IN THIS SECTION:

- » General Operating Safety10
- » Preparing for Initial Start-Up10
- » Normal Starting10
- » Normal Stopping11
- » Sullivan-Palatek Electronic Controller (SPEC) Operational Instructions11
- » Operating Under Extreme Conditions13
- » Pneumatic Tools Application.....13
- » Jump-Starting Battery14

3.1 GENERAL OPERATING SAFETY

- » Allow at least ten feet of unobstructed area in front of cooling air inlets and outlets to assure good airflow.
- » If compressor is connected to a common header with one or more compressors, a check valve must be provided between each compressor and header.
- » Check instruments periodically during operation. If readings are abnormal, refer to *Chapter 6 TROUBLESHOOTING on page 39*
- » Make sure that the correct type and viscosity of lubricating oils and fuel are used, especially in extreme ambient temperatures.
- » Keep batteries fully charged and properly maintained.

3.2 PREPARING FOR INITIAL START-UP

1. Inspect the compressor, engine, and other assemblies for damage or loose connections which might have occurred during shipment.
2. Check the engine's crankcase oil level. If required, add oil as recommended in the Engine Manual, located at www.kohlerpower.com.
3. Check the radiator coolant level. Also, if the machine will be exposed to sub-freezing temperatures, check the specific gravity to ascertain the freezing point of the coolant.
4. Fill the fuel tank with fuel recommended in the Engine Manual.

WARNING! *Never add gasoline to diesel fuel tank - serious damage to the engine will result.*

5. If necessary, add lubricating oil to the compressor sump. Refer to the Lubrication and Maintenance section for lubricating oil specifications.
6. Check battery posts and cable clamps to assure proper contact. Connect positive cable and negative cable battery terminals.

3.3 NORMAL STARTING

1. Inspect the compressor, engine and other assemblies for damage or loose connections.
2. Check engine coolant, oil, fuel, and battery fluid levels. Check compressor receiver oil level.
3. Close service valves.
4. Set start-run valve to **START** position.
5. Press the top of the ignition switch to **ON** position. Allow display to boot up.
6. Press again and hold the top of the ignition switch. This will engage the starter and the engine will turn over. Release the switch when the engine starts. Do not actuate the starter for more than 15 seconds at a time. If the engine does not start, wait for one minute before repeating.
7. Make sure that all warning lights on the control panel are off when the engine is running.
8. Run at minimum speed for a few minutes according to table (except constant speed engine):

AMBIENT TEMPERATURE	TIME
≤ -4°F (-20°C)	2 minutes
from -4°F to 14°F (-20°C to -10°C)	1 minute
from 14°F to 23°F (-10°C to -5°C)	30 seconds
from 23°F to 41°F (-5°C to 5°C)	20 seconds
≥ 41°F (5°C)	15 seconds

9. After warm-up, set Start-Run valve to **RUN** position for full load operation.

CAUTION! *If the engine stops, do not attempt to restart with the oil receiver under pressure. Wait until unit blows down to <10 psi, then return Start-Run valve to **START**.*

NOTE! *For the first 50 hours of engine operation, it is advisable not to exceed 75% of the maximum power supplied.*

3.4

NORMAL STOPPING

1. Position Start-Run valve to **START**. Close all service valves.
2. Run engine at low idle for 2 minutes.
3. Open and close the service valve to reduce pressure to approximately 75 psi or less.
4. Press ignition switch to **OFF**.

3.5

SULLIVAN-PALATEK ELECTRONIC CONTROLLER (SPEC) OPERATIONAL INSTRUCTIONS

The buttons for operation will be referred to numerically based upon the image at right.

Button functionality can vary depending on the operator input required for each page. Pages requiring custom button functionality will display button function icons directly above the buttons.



GAUGE (HOME) SCREEN

The Gauge screen shows current engine and compressor conditions. Additional warnings are displayed within the PSI gauge.

Button 2 will show any fault codes;

Button 3 is the Main Menu button. It activates the Main Menu shown below.



MAIN MENU

This screen allows the user to check user settings, service reminders, set points, and the software version.

Buttons 1 and 2 cycle between the selections;

Button 3 returns back to the Gauge screen;

Button 4 will display any faults;

Button 5 enters into the option selected with buttons 1 and 2.



USER SETTINGS SCREEN

Brightness, contrast, language, units, and time and date can be accessed in this screen.

Buttons 1 and 2 cycle between the selections;

Button 3 returns back to the Menu screen;

Buttons 4 and 5 adjust the setting of the selected item.



SHUTDOWN SET POINTS SCREEN

This screen indicates the setpoints at which shutdowns will occur.

Button 3 returns back to the Menu screen;

Buttons 4 and 5 cycle through the a list of warnings associated with the shutdown setpoints.



SERVICE REMINDER SCREEN

This screen indicates when certain filters should be replaced. A warning icon  will be displayed on the Gauge screen when a filter is due for replacement.

Buttons 1 and 2 cycle through the list of selections;

Button 3 returns to previous menu;
Buttons 4 and 5 move left and right between Filters. *Password for resetting is 0473.*



SOFTWARE SCREEN

The current software and revision level can be found here.

Button 3 returns back to the Menu screen.



DIAGNOSTIC MESSAGE SCREEN

This screen will pop up when the machine encounters a Fault/SPN/FMI code. The specific fault will be displayed, as well as an indication if a shutdown will occur. If a diagnostic fault is hidden, a warning icon ⚠ will be displayed on the Gauge screen.



Buttons 3 or 5 will hide the message;

Button 4 will show other stored fault codes that are still active.

3.6

OPERATING UNDER EXTREME CONDITIONS

Make sure that the correct type and viscosity of lubricating oils and fuel are used, especially in extreme ambient temperatures.

3.6.1 COLD WEATHER OPERATION

- » Use the correct coolant anti-freeze solution and engine oil for the lowest possible temperature expected.
- » When operating the compressor at ambient temperatures below 20°F, use lubricants suited for these conditions. Refer to “5.3 Compressor Lubrication” on page 37 for lubricating oil specifications.
- » Optional starting aids and component pre-starting warming devices are available for some models for cold weather starting.

WARNING!

Do not inject ether starting fluid directly into air intake.

3.6.2 HOT WEATHER OPERATION

- » Keep the engine cooling system filled with clean coolant.
- » Check the coolant level daily or before each shift.
- » Keep the outside of the radiator and oil cooler clean.
- » Locate the unit in a well-ventilated area.
- » When operating in humid conditions, change the compressor oil more frequently.

3.6.3 DUSTY OR SANDY AREAS

- » When possible, wet down the area surrounding the operating site to keep dust and blowing sand to a minimum.
- » Inspect air filters before each operating shift or daily.
- » Keep radiator and oil cooler clean. Check daily and wash or blow clean as needed.

WARNING!

Check the compressor sump oil level only when the compressor is not operating and system is completely relieved of pressure. Open pressure relief valve to ensure relief of system air pressure when performing maintenance on compressor air/oil system. Failure to comply with this warning may cause property damage and serious bodily harm or death.

3.7

PNEUMATIC TOOLS APPLICATION

WARNING!

Compressed air can be dangerous. Serious injury or death can result from the improper selection, use or application of tools and attachments to this compressor.

Never inject compressed air into a bodily orifice. Never direct compressed air at or toward a person or animal.

Do not breathe air produced by a portable air compressor.

- » Install an appropriate flow-limiting valve between the compressor service air outlet and the shut-off (throttle) valve when an air hose exceeding 0.5-inch inside diameter is to be connected to the shut-off (throttle) valve. This is to reduce pressure in case of hose or connection failure, per OSHA Standard 29 CFR 1926.302 (as) (7).
- » When a hose will be used to supply a manifold, install an appropriate flow-limiting valve between the manifold and each air hose exceeding 0.5-inch inside diameter that is to be connected to the manifold. This will reduce pressure in case of hose failure.
- » Provide an appropriate flow-limiting valve for each additional 75 feet of hose in runs of air hose exceeding 0.5-inch inside diameter to reduce pressure in case of hose failure.
- » Flow limiting valves are listed by pipe size and rated CFM. Select appropriate valves accordingly.
- » Do not use tools that are rated below the maximum relief valve rating on this compressor. Do not exceed manufacturer's rated safe operating pressures for these items.
- » Secure all hose connections by wire, chain, or other suitable retaining devices to prevent tools or hose ends from being accidentally disconnected. Unrestrained disconnected hoses can flail around and cause injury or damage.
- » Vent and release all internal pressure prior to opening any line, fitting, hose, valve, drain plug or connection. This includes components such as filters, line oilers and optional air line anti-icing systems.

WARNING! *Serious injury can result from the direct discharge of compressed air. Do not allow personnel to be in line or front of the discharge opening of the service valve, hoses or tools or other points of compressed air discharge.*

Air gun cleaning devices must not be used and pressures above 30 psig (2 Bars). Always use an appropriate regulator to reduce pressure at the cleaning tool and always use with effective chip guarding and personal protective equipment per OSHA Standard 29 CFR 1910.242 (b).

WARNING! *Serious injury or death may result from horseplay with air hoses and compressed air. HORSEPLAY - DO NOT DO IT, DO NOT ALLOW IT!*

3.8 JUMP-STARTING BATTERY

WARNING! *Always wear an acid-resistant apron, face shield with goggles and gloves when working with batteries!*

Batteries may contain hydrogen gas which is explosive and flammable! Keep flames, sparks and any other source of ignition away. Batteries also contain acid which is corrosive and poisonous. DO NOT allow battery acid to contact eyes, skin, or fabrics. Serious personal injury or property damage could result! Flush any contacted areas thoroughly with water immediately and seek medical attention.

NOTE! *The following instructions are for single battery 12 VDC starting systems only. Make sure both compressor and starting vehicle have the ignition "OFF" before connecting the jumper cables.*

1. Remove all vent caps from the battery or batteries in the compressor. Do not permit dirt or foreign matter to enter the open cells.

CAUTION! **Remove vent caps on dead battery if the battery is a maintenance type and add distilled water if needed. This is not required if the battery is a maintenance-free type that is sealed.**

2. Check fluid level. If low bring to a proper level before attempting to jump-start.
3. Locate the starting vehicle beside the compressor, but do not permit metal-to-metal contact between the compressor and the starting vehicle. Set the parking brakes of the compressor (if provided) and the starting vehicle, or chock or block both sides of all wheels. Place the starting vehicle in neutral or park, turn off nonessential accessory electrical loads.
4. Connect one end of the RED (positive) cable to the positive (+) terminal on the dead battery in the compressor. Make sure the other end of this cable does not touch any metal surface that would cause arcing!
5. Connect the other end of the RED (positive) cable to the positive (+) terminal on the good battery in the starting vehicle.
6. Connect one end of the BLACK (negative) cable to the negative (-) post on the good battery in the starting vehicle.

7. Connect the other end of the BLACK (negative) cable to an unpainted metal surface on the compressor engine with the dead battery.
8. Make sure all the jumper cable clips have a good connection (good clamping force) before attempting to start.
9. Start vehicle with the good battery first and let it run a few minutes. Then attempt to start the compressor with the dead battery.
10. If the compressor starts then allow it to warm up and then remove the jumper cables while keeping the compressor running. Make sure not to let the clips of the cables touch while either end of the cables are attached to one of the batteries. This would cause arcing.
11. Replace vent caps on battery if required.
12. Move starting vehicle away from compressor.
13. If compressor engine starting motor will not crank after repeated attempts or the battery is still dead after running the compressor for over an hour (not taking charge), then the battery must be replaced.

4 COMPONENT DESCRIPTION

TOPICS IN THIS SECTION:

- » Portable Compressor Package18
- » Engine.....18
- » Air End Assembly18
- » Discharge System.....18
- » Lubrication System19
- » Capacity Control System.....20
- » Noise Control Systems.....20
- » Electrical and Protective Circuit System.....21
- » Engine Shutdown Protection21
- » Instrument Panel22

4.1 PORTABLE COMPRESSOR PACKAGE

The compressor is a single stage, oil-flooded lubricated rotary screw air compressor. The compressor package is available as a portable wheel-mounted unit, utility mounted unit, or galvanized skid-mounted unit for offshore applications. All models are enclosed in a weather-resistant acoustical enclosure.

The complete operating unit consists of a gas diesel engine for power, compressor assembly, air/oil separator system, cooling system for the engine and compressor oil, instrumentation, pneumatic control system, and acoustical enclosure.

4.2 ENGINE

The compressor is powered by a diesel gas/LPG engine. For detailed information on the engine refer to the Engine Operators , located at www.kohlerpower.com Manual provided with each compressor.

4.2.1 ENGINE COOLING SYSTEM

The engine cooling system utilizes a conventional engine radiator, thermostat, water pump, and fan to maintain the engine coolant at a desired operating temperature.

4.2.2 ENGINE TO COMPRESSOR DRIVE

The compressor and engine are connected through a non-lubricated spline coupling. It consists of a drive ring registered and bolted directly to the engine flywheel and either a splined hub or a disc attached to the compressor drive shaft. Because of low starting torque, no clutch is required.

4.3 AIR END ASSEMBLY

The compressor assembly is an oil flooded, positive displacement, single-stage rotary screw unit. Components include a stator housing, male and female rotors, bearings, and bearing supports. Engine power is transferred to the male rotor through a coupling and, if a gear-driven unit, through gears in the gear housing. The male rotor drives the female rotor.

4.3.1 COMPRESSION CYCLE

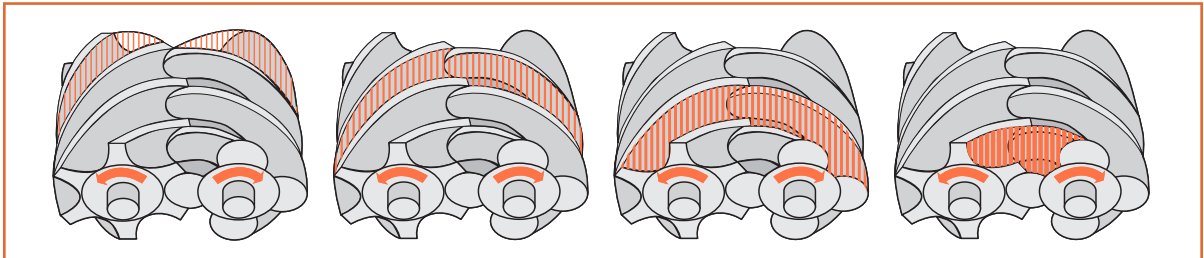

FIGURE 4-1. COMPRESSION CYCLE

Air at atmospheric pressure is drawn in through the inlet and compressed by the rotation of the rotors. During the compression cycle, oil is injected into the compressor performing three important functions:

1. Lubricate the rotating parts and bearings.
2. Provide cooling for the compressed air.
3. Seal the running clearances between the rotors.

4.4 DISCHARGE SYSTEM

4.4.1 RECEIVER/SUMP

From the compressor discharge, oil-laden air enters the receiver/sump tank above the oil level and most of the oil is separated from the air by gravity. The oil runs downward and accumulates for recirculation, while the remaining oil mist passes through the separator element. The oil separator is located on top of the manifold. When air is demanded at the service line, it passes through the separator element, which provides the final stages of air/oil separation.

4.4.2 MINIMUM PRESSURE VALVE

The minimum pressure valve is located at the service air outlet (at the top of the separator). This valve serves to maintain a minimum discharge pressure of 65 to 80 185 to 215 psig in operation, which is required to assure proper air/oil separation. At normal operating pressure of 90 psig 250 to 125 150 to 500 psig, this valve is wide open effectively removing any restriction to airflow.

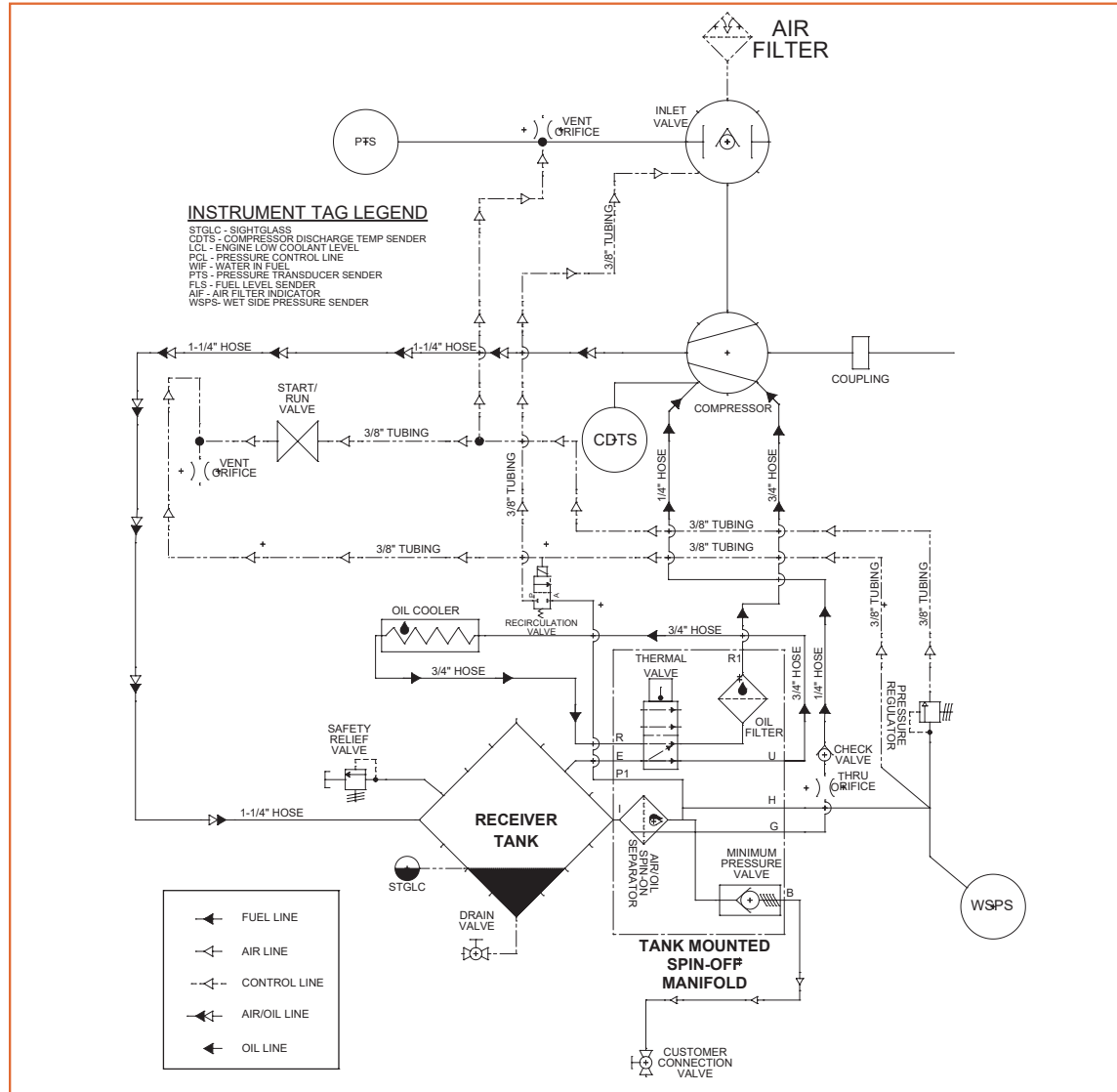

FIGURE 4-2. DIAGRAM, PLUMBING AND INSTRUMENTATION

Oil from the compressor oil sump at compressor discharge pressure is directed through the cooling system and oil filter to a lower pressure region of the compressor stator. At the same time, oil is directed to the bearings and shaft seal of the compressor. The oil-laden air is then discharged back into the sump.

The compressor cooling system consists of an oil cooler mounted adjacent to the engine radiator. Cooling air is pushed through the cooler by the engine fan while oil is circulated through it by the receiver/sump pressure.

4.5.1 OIL RETURN LINE

The oil that is not removed by the air/oil separator gravitates to the bottom of the air/oil separator stem and is returned through an orifice in the oil return scavenger line assembly. The assembly consists of a pickup tube, return line hose and an , a line strainer and a sight glass/orifice/check valve. Flow can be observed through the sight glass. Flow is generated via differential pressure between the high pressure sump tank and the lower pressure region of the compressor.

4.5.2 OIL FILTER

A full-flow canister-style oil filter is supplied to protect the compressor unit from solid contaminants. The filter has an internal bypass valve to assure adequate oil flow with cold oil or a plugged oil filter element. The filter canister can be removed with a strap wrench.

4.5.3 THERMAL BYPASS VALVE

The thermal bypass valve is the center of the compressor temperature regulating system. The valve is designed to be fully open, allowing the oil to bypass the cooler until the oil temperature rises. Above the thermostat set point the valve gradually closes down and becomes completely closed when the oil temperature reaches the thermostat set point.

4.6 CAPACITY CONTROL SYSTEM

The control system is designed to match air supply to air demand and to prevent excessive discharge pressure when the compressor is operating but air is not being used. Control of air delivery is accomplished by both by inlet valve regulation and engine speed control as directed by the adjustable discharge pressure regulator valve.

The following overview explains the operation of the control from a condition of “no load” to a condition of “full capacity” at working pressure. For the working pressure range of your machine, refer to applicable data in the Specifications section.

The inlet valve cylinder pressure chamber is pneumatically connected to the dry side of the receiver via the pressure regulator valve. When the receiver tank pressure is below the set point of the regulator valve no pressure will exist in the inlet valve chamber. Under these conditions, the inlet valve will remain wide open, causing the compressor to deliver full capacity.

As the demand for air decreases, the receiver pressure will rise, and when this pressure level exceeds the set point of the pressure regulator valve, control signal pressure will be allowed to enter the inlet valve chamber, which in turn will move the modulating piston and the valve plate to a closed condition, thereby throttling the incoming air.

When less than full capacity is required, receiver pressure increases, thereby opening the pressure regulator, which allows a signal from the pressure transducer to reduce the engine speed until it matches the air requirements from 100% down to 60%. From 60% down to 0% both engine speed reduction and inlet valve modulation act together to reduce air output.

NOTE!

The compressor can only produce its maximum rating of air flow at rated pressure (rated CFM at rated psig). If the tank pressure continues to decrease when the machine is at full speed and the inlet valve fully open, a larger capacity compressor or multiple compressors may be required for the customer's job needs.

4.6.1 INLET VALVE

The inlet valve assembly is the heart of the control system, which regulates the amount of air entering the compressor. The engine speed is regulated by the Sullivan-Palatek Electronic Controller (SPEC). From full to approximately 60% capacity, the delivery is controlled by engine speed and gradual closing of the inlet valve. When unloaded the inlet valve is closed to prevent atmospheric air from entering the compressor.

4.6.2 START -RUN VALVE

The Start-Run valve is used to bypass the compressor pressure regulator valve. This results in reduced engine load at start-up. Once the engine is warmed up, the valve can be moved to the RUN position. In the START position, the start-run valve is open. In the RUN position, it is closed.

4.6.3 AUTOMATIC BLOWDOWN VALVE

The automatic blowdown valve relieves pressure in the system upon shutdown. It is closed when the compressor is in operation; however, at shutdown, the inlet valve closes, the unit becomes pressurized and sends a pressure signal to open the normally closed blowdown valve.

4.6.4 RECIRCULATION VALVE

The recirculation valve allows air under the inlet to keep the compressor from cavitating, thereby increasing air end life. The recirculation valve functions automatically in response to the regulated control pressure. When it receives the unload signal to the inlet valve, the recirculation valve opens, allowing a small amount of pressurized sump air to be recirculated through the compressor. This air holds a positive pressure signal on the inlet side of the air end to prolong the shaft seal life.

4.7 NOISE CONTROL SYSTEMS

Noise control systems incorporated in this compressor have been designed to meet the requirements of federal noise control regulations. The principal components of the noise control systems include the enclosure, engine exhaust system, and compressor intake system. The enclosure has been designed to provide the required noise reduction while maintaining a good distribution of cooling airflow to the radiator and oil cooler.

4.8 ELECTRICAL AND PROTECTIVE CIRCUIT SYSTEM

The compressor electrical system is a 12-volt negative ground system used on smaller-capacity (185–375 CFM) compressors and a 24-volt negative ground system used on larger-capacity (750–1800 CFM) compressors. It is equipped with a protective circuit to minimize damage. Damage could be caused by high compressor discharge temperature, high engine water temperature, or low engine oil pressure. Refer to wiring diagrams as required. The following conditions will cause automatic shutdown of the compressor:

- » Compressor discharge temperature (CDT) of approximately 280°F (138°C) 265°F (129°C). A warning is shown when the temperature reaches 245°F (118°C) and the unit will be forced to unload.
- » Low engine oil pressure (EOP) dependent upon engine manufacturer's specifications.
- » High water temperature (EWT) dependent upon engine manufacturer's specifications.

4.9 ENGINE SHUTDOWN PROTECTION

Sullivan-Palatek Group uses electronically controlled engines in the 185–1800 CFM line of compressors. Personnel operating and maintaining these compressors MUST be familiar with and understand the operation and protection features available with these engines.

WARNING! *Failure to follow the electronic control warnings and attempts to override, bypass, or ignore these warnings can lead to severe engine damage. This damage will not be covered by either the engine manufacturer's or Sullivan-Palatek's Group's warranty.*

Electronically controlled engines have software that monitor engine parameters during operation. If the parameters exceed the normal operating threshold, the engine software will take appropriate actions to protect the engine from damage. There are two levels of action: derate and shutdown. If either of these actions are initiated, the software will also activate the yellow warning sign and red engine shutdown/diagnostic warning sign on the Sullivan-Palatek Electronic Controller (SPEC).

4.9.1 ENGINE DERATE

The engine will derate the power output of the engine in an attempt to correct the parameters that are out of range. In almost every case, power deration will result in the engine stalling, which will protect the engine from damage.

NOTE! *The yellow warning will be lit on the SPEC screen when this occurs.*

4.9.2 ENGINE SHUTDOWN

The second level of protection in the controller is engine shutdown. If the derate feature cannot correct the unsafe parameters or the engine does not stall, the controller will shut down the engine to protect it from damage.

NOTE! *The warning and shutdown information will be lit on the SPEC screen when this occurs.*

If either of these protection features activate, the engine requires inspection by an authorized engine manufacturer's Dealer before attempting to run the machine again.

WARNING! *Failure to inspect and correct the fault in the engine or at the point of the external sensor will result in repeated derates and shutdowns, which can lead to engine damage.*

NOTE! *The engine software stores all derate and shutdown information to be reviewed by the engine manufacturer's representative. Attempts to restart the compressor without repairing the fault sensed by the protection system will be recorded in the engine software and will void the engine manufacturer's warranty. The Sullivan-Palatek Group warranty DOES NOT COVER the engine. The engine and its components are warranted only by the engine manufacturer.*

Operators, rental customers and anyone responsible for the operation and maintenance of this compressor MUST be instructed and briefed on the proper responses to control module warnings. In particular, they must be instructed to report warning instances and not attempt to restart the compressor until faults are cleared by certified personnel.

4.10

INSTRUMENT PANEL

The instrument panel contains all the necessary controls and instrumentation for operation. It is enclosed by a lockable, hinged door. Following is an explanation of the principal controls and instruments:

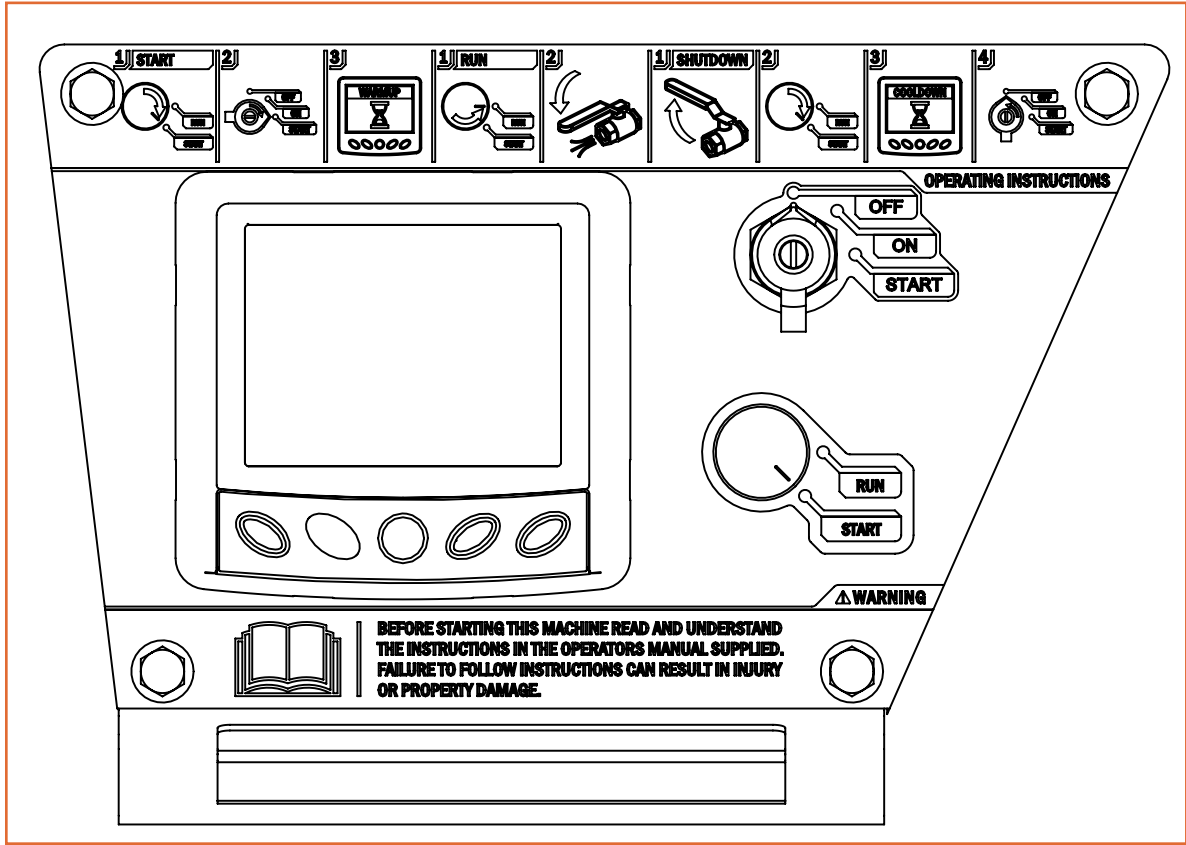

FIGURE 4-3. INSTRUMENT PANEL

ITEM	NAME	DESCRIPTION
1	Sullivan-Palatek Electronic Controller (SPEC)	Monitors the engine and compressor parameters, displays warning and shutdown information, and displays engine diagnostic information from the engine ECU.
2	Ignition Switch	ON position electrically energizes engine starter motor solenoid.
3	Start-Run Valve	START allows compressor to be started. RUN allows full-load operation.

4.10.1 SULLIVAN-PALATEK ELECTRONIC CONTROLLER (SPEC) MODEL PV4380

The Sullivan-Palatek Electronic Controller (SPEC) Model PV4380 monitors all critical compressor and engine parameters, provides warning and shutdown information and has complete engine diagnostic capabilities. Parameters monitored by the SPEC include engine speed, compressor temperature, engine oil pressure, engine temperature, battery voltage and fuel level. The SPEC provides warning and shutdown information from high compressor temperature and low fuel level. It also has complete engine diagnostic capabilities that can read and display fault codes from the engine ECU. Multiple language options are available including English, Spanish, French, Italian and German.

NOTE!

Engine derate and derate and shutdown are controlled by the engine ECU and displayed on the SPEC. For more information about the SPEC display, refer to page 1113.

DEFAULT KEYPAD FUNCTIONS

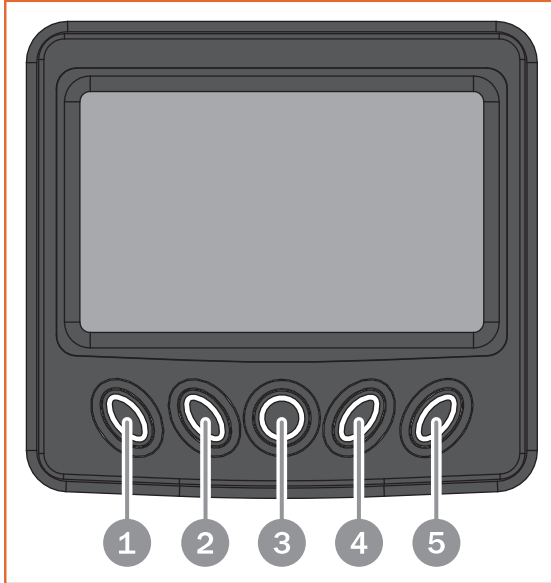

FIGURE 4-5. SPEC KEYPAD

BUTTON	NAME	FUNCTION
1	Soft Key 1	Previous Page
2	Soft Key 2	Decrease Contrast
3	Soft Key 3	Settings / Gauge Display
4	Soft Key 4	Increase Contrast
5	Soft Key 5	Next Page

NOTE! Pages with unique button functions will display functionality with a symbol directly above the buttons.

NOTE! IGNITION SWITCH

The ignition switch has 3 functions:

- » In the **ON** position the SPEC/engine display will be powered up. Once the instrument cluster is displayed, the machine is ready to start.
- » In the **START** position the ignition is used to electrically energize the engine starter.
- » The **OFF** position should be used only when the machine is ready to be shut down.

When the **START** button is pressed on the ignition switch, the engine starter motor solenoid is electrically energized. Using the **STOP** button puts the machine into a mandatory cooldown state.

4.10.2 START-RUN VALVE

The Start-Run (load-unload) valve unloads the compressor for easier start-up. When positioned on **START** this valve bypasses the pressure regulating valve so that the inlet valve closes with reduced discharge pressure. After the compressor is warmed up, the Start-Run valve can be turned to **RUN** position. The unit is then ready for full-load operations.

Prior to shutdown, the Start-Run valve must be turned to the **START** position and the service valve opened and closed to reduce pressure to approximately 75 psi or less. Shutdown under full load can damage the compressor and put unnecessary strain on the drive components. **CAPACITY/PRESSURE SWITCH**

5 MAINTENANCE

TOPICS IN THIS SECTION:

» Maintenance Schedule	26
» Bolt Torque Guidelines	27
» Compressor Lubrication	27
» WEATHER-ALL™ Compressor Lubricant	28
» Oil Sample for Analysis	29
» Air Intake Filter	30
» Compressor Oil Filter	30
» Compressor Shaft Oil Seal	30
» Oil Return Line	30
» Air/Oil Separator	31
» Thermal Valve	31
» Oil Cooler	31
» Grease	31
» Engine Lubrication	31
» Control Adjustments	32
» Recommended Spare Parts	34
» Service Kits	34

5.1 MAINTENANCE SCHEDULE

MAINTENANCE SCHEDULE										
PROCEDURE	FREQUENCY (HOURS)							AS REQUIRED	SEE NOTE	REF.
	DAILY	50	250	500	1000	2000	5000			
Check oil level (before starting)	x								1	5.3
Check radiator coolant level	x								1	
Check fuel supply (after starting)	x								1	
Check air filter elements	x								1,7	5.6
Check for fuel, oil air and water leaks	x								1	
Drain water from compressor sump		x							2	
Drain water and sediment from fuel tank		x							2,7	
Change oil filter element		x		x					6	5.7
Change compressor oil					x			x	5	5.3, 5.4
Clean engine radiator heat-exchange surface and intercooler			x						9	
Check drawbar and bolt torque			x						3	5.2
Check wheel lug nuts			x						3	
Check tire pressure			x						3	
Inspect lifting frame (before each lift)			x						3	
Check alternator belt tension			x						9	
Replace fuel prefilter Type A			x						5, 9	
Replace fuel prefilter Type B				x					5, 9	
Replace fuel filter cartridge				x					5, 9	
Check engine hoses and clamps (radiator, intake air, fuel)				x					4	
Repace alternator belt				x					9	
Replace engine coolant					x				8, 9	
Change compressor air filter element					x				4,7	5.6
Check axle spring shackles and mounting bolts					x				4	
Clean battery terminals					x				4	
Check battery hold-downs and cables for wear					x				4	
Check compressor shaft seal for leaking					x				4	5.8
Check air filter piping, fittings and clamps					x				4	
Check engine and compressor supports					x				4	
Replace air/oil separator element					x				5	5.10
Check all door gaskets, hinges and latches						x			5	
Drain engine radiator coolant and replace						x			5, 9	
Clean and flush cooling system						x			5	5.12
Check protective circuits and verify proper function						x			5	
Check sump pressure relief valve						x			5	
Check starter motor							x		9	
Check alternator							x		9	
Replace engine hoses (radiator, intake air, fuel)							x		7, 9	
Inspect and clean oil system thermostat								x	6	
Check control adjustment								x	6	5.15
Re-pack wheel bearings								x	6	
Replace engine dry air cleaner external cartridge									After 6 checks with cleaning	7, 9

NOTES

1. Or every 10 hours of operation or on rent return
2. Or weekly
3. Or before returning to ready line
4. Or 6 months
5. Or annually
6. After first 50 hours of operation
7. More frequently in extreme operating conditions (dusty, humid, low temperature)
8. Or 24 months if low usage
9. For complete engine maintenance, refer to the engine manufacturer's maintenance manual at www.kohlerpower.com

5.2 BOLT TORQUE GUIDELINES

5.2.1 INCH FASTENERS

INCH FASTENERS TORQUE				
Size	SAE Grade 5 (ft-lb)		SAE Grade 8 (ft-lb)	
	Dry	Oiled	Dry	Oiled
¼-20	8	6	12	9
⅝-18	17	13	25	18
⅜-16	30	23	45	35
⅞-14	50	35	70	55
½-13	75	55	110	80
⅙-12	110	80	150	110
⅝-11	150	110	220	170
¾-10	260	200	380	280

5.2.2 TORQUE SEQUENCE

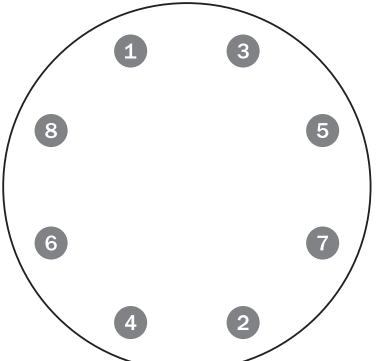
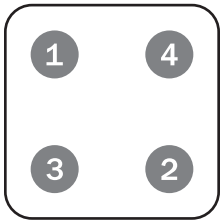
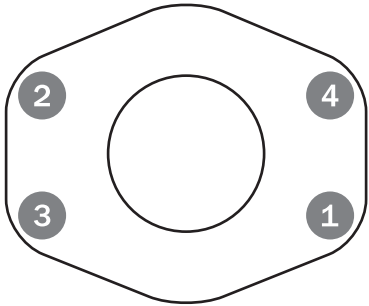
TYPICAL BOLT TORQUE PATTERNS		
Circular Pattern (8-Bolt)	Square Pattern	Flange Pattern
		

5.3 COMPRESSOR LUBRICATION

Change oil at least once a year, even if the normal oil change period in hours has not yet been reached.

CAUTION!

Never mix synthetic lubricants with hydrocarbon lubricants. Never mix synthetic lubricants manufactured from different base products. Severe damage to the compressor system may result.

Contamination of non-detergent mineral oils with traces of ATF, or detergent motor oils, may lead to problems such as foaming and plugging of filters, orifices, and lines. Lubricant manufacturers include a variety of additives in the blending process to enhance lubrication, product life and performance. Mixing different types or brands of lubricants is not recommended due to the possibility of a dilution of the additives or a reaction between additives of different types.

Environmental conditions in the area of compressor operation such as the presence of reactive gases or vapors in the air may lead to chemical changes and premature degradation of the lubricant. The useful life of synthetic lubricants may extend the normally recommended drain and replace period; however, the user is encouraged to closely monitor the lubricant condition and to participate in an oil analysis program with the fluid supplier. When ambient conditions exceed those noted, or if conditions warrant use of “extended life” lubricants, contact Sullivan-Palatek for a recommendation.

5.3.1 CHECK

The oil level should be checked daily.

1. Shut down the compressor (or check before the compressor is turned on).
2. Wait two minutes after the compressor stops to allow the pressure to be relieved and the oil to settle.
3. Observe the oil level in the fluid sight glass. The fluid sight glass should be ½ to ⅔ full.
4. While the compressor is running, the oil should be visible in the sight glass.

5.3.2 FILL

Before adding or changing compressor oil, completely relieve the sump of pressure. Venting the sump tank pressure relief valve will do this. Oil is added at the fill plug.

5.3.3 LEVEL

The proper oil level, when unit is shut down and oil has had time to settle, is across the center of the oil level sight glass. For oil sump capacity, refer to the Parts & Specifications Manual.

WARNING!

Compressor must be shut down and pressure completely relieved from system before checking fluid levels. Open pressure relief valve to assure relief of system air pressure. Failure to comply with this warning may cause property damage and serious bodily harm or death.

5.3.4 DRAIN

Always warm compressor thoroughly prior to changing the compressor oil. When changing the oil, make sure system is completely drained to reduce potential contamination.

WARNING!

Do not attempt to drain water, remove the oil level fill plug, or break any connection in the air or oil system until all the pressure has been relieved. Check by manually opening the sump pressure relief valve. Serious injury or death may result if this warning is not followed.

5.4

WEATHER-ALL™ COMPRESSOR LUBRICANT

All of Sullivan-Palatek's portable air compressors are initially filled with Sullivan-Palatek's WEATHER-ALL HP™ Compressor Fluid at factory. This custom-formulated, multi-viscosity 5W-20 lubricant is specifically designed for long life under severe, demanding conditions. Maximum protection against scuffing and wear to bearings and rotors, and wear-control for steel and brass parts when operating at maximum pressure ratings results in extended compressor life. Extensive testing has shown this fluid exhibits excellent resistance to foaming, oil oxidation and corrosion of yellow metals and limits rust of ferrous metals.

This synthesized hydrocarbon-based fluid provides quick water separation which enhances equipment protection in wet and humid service environments. It offers an excellent viscosity index of 180 as well as low pour point of -40°F.

Sullivan-Palatek strongly advises the continued use of WEATHER-ALL to ensure optimal compressor performance, and lower equipment maintenance costs.

LUBRICANT SPECIFICATIONS			
ISO Viscosity Grade	32	Normal Service Life	1000 hours*
SAE Viscosity Grade	5W-20	Viscosity Index	180
Viscosity, cst. 210°F	50 SUS	Pour Point	-40°C / -40°F
Viscosity, cst. 100°F	170 SUS	Flash Point	199°C

NOTE!

These values are not intended for use in preparing specifications.

*Service life is only a guideline for typical oil life if temperature is the only variable to be considered. Many variables affect the oil life, i.e. environmental impact from various gases, dust and dirt, compressor short cycling, etc.

Sullivan-Palatek recommends oil sampling as the best guide for your fluid change interval. Changing fluid once a year may not be adequate or it can be excessive. For this reason an hourly service on lubricants is merely a guide. Please consult your factory-trained servicing distributor for questions concerning your lubricant life and Sullivan-Palatek's lubricant sampling program.

5.5

OIL SAMPLE FOR ANALYSIS

The first oil sample should be drawn after the compressor has run for 500 hours or 3 months. Intervals for following oil samples will be determined by the analysis results.

SAMPLE OIL FROM SUMP TANK

1. Run the compressor long enough to reach normal operating temperatures.
2. Turn compressor OFF and allow pressure to blow down to 0 psi.
3. Remove the drain plug from the end of the drain line at the bottom of the sump tank.
4. Open the drain valve and drain any water from the sump tank. Discard in an approved manner.
5. Fill the clear sample bottle (2) with oil. The sample bottle (2) must be at least one-third full.
6. Close the drain valve and replace the plug in the drain line.
7. Start the compressor according to 3.3 *Normal Starting* procedures.
8. Check the oil level during operation. Add oil if necessary according to 5.3.2 *Fill* procedures.

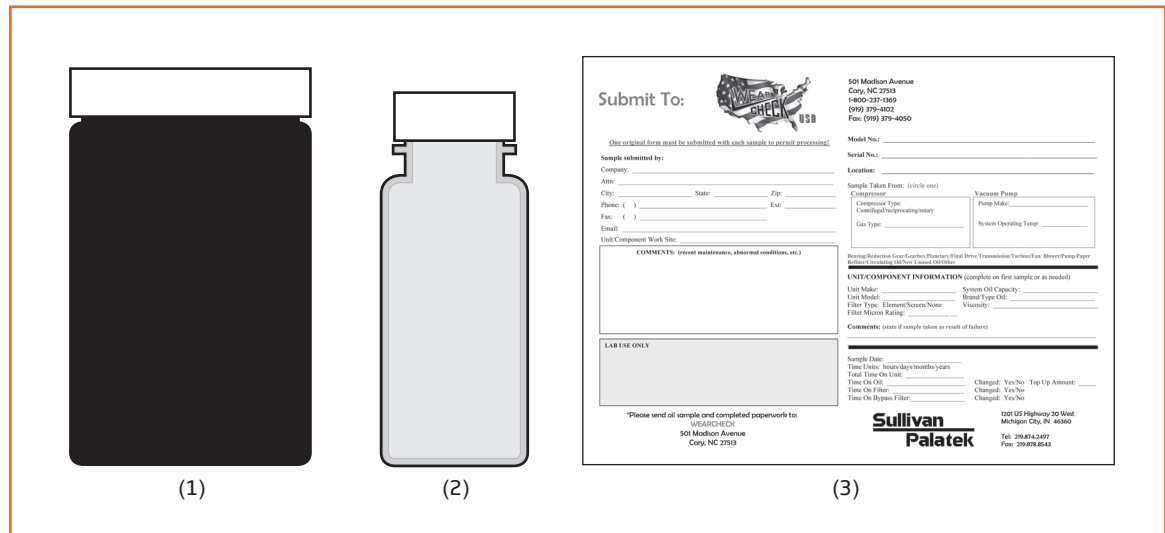

FIGURE 5-1. OIL ANALYSIS KIT (P/N K00031-005)

SUBMIT OIL SAMPLE

1. Fill out all the information on the oil sample form (3) provided with the oil analysis kit. Please make sure the form is completely and legibly filled out.
2. Place the oil sample bottle (2) inside the black canister and put the lid on.
3. Mail the sample with the form to:
Wear Check
501 Madison Avenue
Cary, NC 27513

INTERPRET RESULTS

Once the sample is processed the laboratory will e-mail the results of the oil analysis to the sender of the sample. The analysis report includes customer unit information, sample data, spectrochemical analysis, physical properties, additional test results and analysis recommendations. If previous oil samples have been submitted for analysis, that information will also be on the report. Information to assist in understanding the analysis report is included on the front of the report.

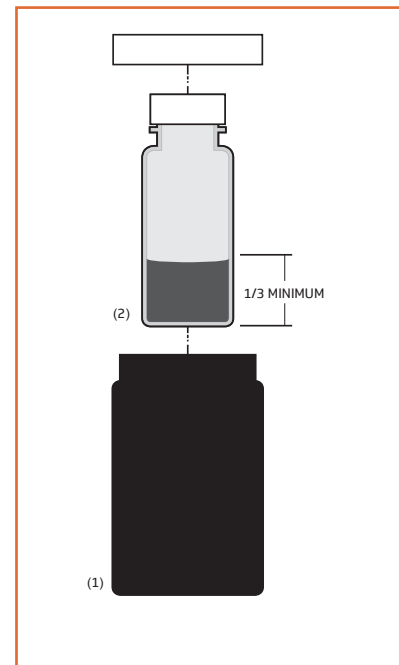

FIGURE 5-2. BOTTLE PREPARATION

5.6 AIR INTAKE FILTER

Check daily, every 10 hours of operation or on rent return. Replace filter element every 1,000 hours or 6 months. Replace more frequently in dusty conditions. Empty the evacuator valve (dust boot) daily.

5.6.1 REMOVAL AND INSPECTION

1. Unscrew wingnut on air filter cover and remove cover.
2. Unscrew primary air filter element wingnut; pull used element to remove.
3. Remove and inspect the secondary filter by unscrewing wingnut and pulling element.
4. The air filter elements should be thoroughly inspected for holes by placing a lamp inside the element and carefully checking for areas of bright light passing through the element and seal.

5.6.2 INSTALLATION

1. Insert new filter element(s) and tighten wingnut(s).
2. Place cover back on air filter and tighten wingnuts and close locking devices.

5.7 COMPRESSOR OIL FILTER

Replace the oil filter element once after the first 50 hours of operation, then every 500 hours. Replace more frequently in extreme operating conditions.

5.7.1 INSPECTION

The compressor oil filter should be checked to ensure the correct element is properly installed and not leaking.

5.7.2 REMOVAL

1. Make sure the system pressure is relieved.
2. Place oil spill pan under filter.
3. Remove oil filter element by unscrewing it from the filter head (turn counter-clockwise) and discard. The use of a strap-type wrench may be necessary.

5.7.3 INSTALLATION

1. Apply a thin film of oil to the seal of a new oil filter.
2. Thread the oil filter on by hand, turning it clockwise until the gasket seats. Then turn an additional $\frac{1}{2}$ to $\frac{3}{4}$ turn by hand.
3. Check for leaks in operation.

5.8 COMPRESSOR SHAFT OIL SEAL

Check the compressor shaft seal for leaking oil every 1,000 hours or 6 months.

5.8.1 INSPECTION

Inspect the compressor shaft seal for signs of leaking oil.

NOTE!

If replacement is necessary, removal and installation instructions will be provided with the shaft seal kit.

5.9 OIL RETURN LINE

Check the oil return line periodically to make sure that it does not become clogged. A clogged line results in excessive oil consumption and oil in the service lines.

5.9.1 INSPECTION

Inspect oil return line for clogging.

5.9.2 CLEANING

If clogging is indicated, check and clean the entire line, including the orifice fitting at the manifold. Blowing with a reverse flow of compressor air will clean the line.

5.10 AIR/OIL SEPARATOR

Replace the air/oil separator every 1,000 hours, annually, or when differential exceeds 10 psi. The air/oil separator employs a unitized element.

The separator element is a single piece unit, which requires replacement when it fails to remove the oil from the discharge air. Prior to replacing the separator element be sure to check the oil return line and orifice for plugging or restrictions.

WARNING! *The combination of a build-up of dirt and oxidized oil can clog the element causing an increase in air velocity at narrow points on the element media. Elevated temperatures at these points can result in ignition of the fluid in the oil sump.*

5.10.1 REMOVAL

1. Relieve sump pressure to zero pressure.
2. Unscrew air/oil separator element by turning counter-clockwise.
3. Remove the old element and discard in accordance to local codes.

5.10.2 INSTALLATION

1. Apply a thin film of oil to the seal of a new element.
2. Thread the element on by hand, turning it clockwise until the gasket seats. Then turn an additional $\frac{1}{4}$ turn by hand.

5.11 THERMAL VALVE

Inspect and clean the thermal valve if the unit shuts down because of high compressor discharge oil temperature.

5.11.1 INSPECTION

Inspect the valve by removing it from the manifold housing. Sediment particles may lodge in the valve-seating surface and prevent it from opening, thereby allowing hot oil to pass directly to the compressor without being cooled.

5.12 OIL COOLER

The interior of the oil cooler should be cleaned when the pressure drop across the cooler at full load exceeds 25 psi.

5.12.1 INSPECTION

Inspect compressor oil system for signs of varnish.

5.12.2 REMOVAL

1. Drain compressor fluid.
2. Remove oil cooler.

5.12.3 CLEANING

Circulate a suitable solvent to dissolve and remove varnish and sludge.

5.12.4 INSTALLATION

1. Replace oil cooler and fill compressor with fresh oil.
2. Operate the machine normally for 50 hours. After 50 hours, change compressor oil and install a new oil filter element.

5.13 GREASE

Use a multi-purpose type grease (MKG) or multi-purpose type grease with molybdenum disulfide (MPGM) conforming to MIL-L-7866 for all parts except wheel bearings. Use wheel-bearing grease (WBG) for lubricating the wheel bearings.

5.14 ENGINE LUBRICATION

Refer to Engine Operation and Maintenance Manual, located at www.kohlerpower.com for recommended engine lubricating oil, service intervals, and maintenance practices.

5.15

CONTROL ADJUSTMENTS

The engine speed governor and pressure regulator are preset at the Factory and normally require no servicing. However, if it becomes necessary to make adjustments, use the following procedures:

5.15.1 DISCHARGE PRESSURE ADJUSTMENT

Unit must be in **RUN** mode before adjusting, and with the service valve(s) closed.

To increase pressure, loosen locknut on pressure regulator adjustment screw and turn screw clockwise. Lower the operating pressure by turning screw counter-clockwise. Reset locknut after adjustment is completed. See *Figure 5-3*.

Check engine speed whenever pressure settings have been changed. Only the unloaded pressure can be selected with the pressure regulating valve. Full and part load pressures are a function of air usage.

5.15.2 ENGINE SPEED

Engine speed is controlled by the Sullivan-Palatek Electronic Controller (SPEC). The full load and idle speeds are programmed at the Factory and there should be no need for adjustment. If the machine is experiencing speed problems please contact our Service Department.

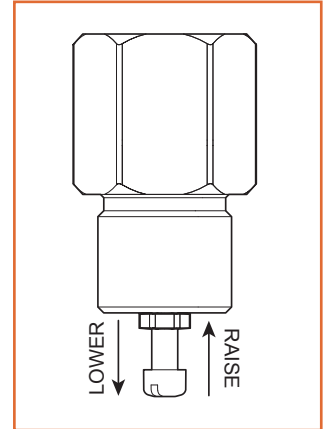

FIGURE 5-3. PRESSURE REGULATING VALVE

2.16

RECOMMENDED SPARE PARTS

D185PIZP

ITEM	PART NUMBER	DESCRIPTION	QTY
1	01900522-0161	PRIMARY AIR FILTER ELEMENT	2
2	01900522-0162	SECONDARY AIR FILTER ELEMENT	2
3	01900522-0143	ELEMENT, OIL FILTER (ENGINE)	1
4	01900522-0139	ELEMENT, FUEL FILTER (PRIMARY)	1
5	01900522-0140	ELEMENT, FUEL WATER SEPARATOR	1
6	05017450-0055	AIR FILTER CAP	2
7	01900184-0009	DUST BOOT	2
8	01900520-0012	COMPRESSOR OIL FILTER ELEMENT	1
9	00600701-0406	SWITCH, IGNITION	1
10	00543117-0040	AIR/OIL SEPARATOR	1
11	01900152-0071	BELT, FAN	1
12	00717708-0004	KIT, SERVICE, INLET VALVE 108MM	1
13	00717708-0001	KIT REPAIR 1.25" MVP	1
14	K0001-005	KIT, OIL SAMPLE W/O Q.F.	1
15	00717708-0021	KIT DRIVE COUPLING REPLACEMENT/INSTALLATION AND DRAWING	1
16	05019660-0012	BLOW DOWN VALVE	1
17	05019205-0009	PRESSURE SENDER	2
18	05019610-0032	MINIMUM PRESSURE VALVE	1
19	05019505-0035	OIL THERMO VALVE	1
20	00519456-0013	RECIRCULATION VALVE	1
21	09661-002	REGULATOR VALVE	1
22	03100-008	SAFETY VALVE	1
23	05019820-0002	VLV,2-WAY 1/4 NPT	1
24	05019415-0053	TEMPERATURE SENDER SWITCH	1
25	00906362-0100	SEALING WASHER	4
26	01901240-0086	KIT,O-RING BASE FLG SPIN-OFF MANF	1
27	05018844-0013	DISPLAY	1
28	05017457-0030	RADIATOR CAP	1
29	KB09147-362	KIT,SHAFT SEAL 3LIP,CW	1

NOTE!

Use only service parts supplied or recommended by Sullivan-Palatek. Use of substitutes may void warranty. See **STANDARD WARRANTY** for details.

2.17

SERVICE KITS

Service kits are available for basic servicing of the compressor and engine. There are annual kits (wet or dry) for a year's worth of compressor and engine servicing and line service kits for a single compressor and engine service.

DESCRIPTION	CONTENTS	PART NUMBER
SERVICE KIT, ANNUAL (WET)	4 ELEMENT, AIR FILTER (PRIMARY) 4 ELEMENT, AIR FILTER (SECONDARY) 2 ELEMENT, OIL FILTER (COMPRESSOR) 2 ELEMENT, OIL FILTER (ENGINE) 2 ELEMENT, FUEL FILTER 2 FLUID, COMPRESSOR WEATHER-ALL (5 GALLON)	00717701-0205
SERVICE KIT, ANNUAL (DRY)	4 ELEMENT, AIR FILTER (PRIMARY) 4 ELEMENT, AIR FILTER (SECONDARY) 2 ELEMENT, OIL FILTER (COMPRESSOR) 2 ELEMENT, OIL FILTER (ENGINE) 2 ELEMENT, FUEL FILTER	00717701-0206
SERVICE KIT, LINE (WET)	2 ELEMENT, AIR FILTER (PRIMARY) 2 ELEMENT, AIR FILTER (SECONDARY) 1 ELEMENT, OIL FILTER (COMPRESSOR) 1 ELEMENT, OIL FILTER (ENGINE) 1 ELEMENT, FUEL FILTER 1 FLUID, COMPRESSOR WEATHER-ALL (5 GALLON)	00717701-0207

6 TROUBLESHOOTING

TOPICS IN THIS SECTION:

» Introduction.	36
» Unplanned Shutdown	36
» Discharge Pressure Is Too Low.	36
» Discharge Pressure is Too High or Relief Valve Blows	37
» Relief Valve Blows with Throttle Lever in Idle Position.	37
» Pressure Does Not Blow Down After Shutdown	37
» Compressor Oil Level is Decreasing Excessively	37
» Oil in Service Line	37
» Engine Does Not Accelerate Or Will Not Maintain Full Load Speed.	38
» Separator Plugging	38
» Engine Speed Control Does Not Change to Idle Speed with Service Valves Closed.	38
» Engine Speed Control Does Not Change to Full Speed with Air Demand.	38
» Compressor Oil Leaking in Control Lines/Orifices	39

6.1 INTRODUCTION

This section contains instructions for troubleshooting the equipment following a malfunction. Each issue or problem is followed by a list of probable causes and suggested actions to be followed in order to eliminate the cause.

The actions listed should be performed in the order listed, although the order may be varied if the need is indicated by conditions under which the problem occurred. The action which can be performed in the least amount of time and with the removal or disassembly of the fewest parts should be performed first.

6.2 UNPLANNED SHUTDOWN

POSSIBLE CAUSE	ACTION
Engine fault codes present	Machine not out of warm-up mode; allow machine to complete warm-up.
High compressor discharge temperature	Check compressor oil level; add as needed. Clean the coolers and pressure check. Check the fan belt tension. Adjust or replace as needed. Verify correct operation of thermal by-pass valve. Change compressor oil and oil filter element. Clean oil cooler internally. Inspect and clean the thermal by-pass valve by removing valve from bypass housing. Sediment particles can lodge in the valve-seating surface and prevent from closing, allowing hot oil to pass directly to the compressor without being cooled.
Water or contamination in fuel filter	Replace all fuel filters and drain the water from the fuel tank(s).
Low engine coolant and/or high engine coolant temperature	Check the engine coolant level. Add as needed. Clean the coolers. Check the fan belt tension. Adjust or replace as needed. Refer to Engine Manufacturer's manual.
Low engine oil pressure fault code	Check engine oil; add as needed. Verify the engine oil pressure exceeds engine manufacturer's recommended pressure with the engine running.
Obstruction in radiator and/or oil cooler	Remove any external obstructions and clean the coolers.
Improper fan belt tension	Adjust or replace the fan belt or tensioner as needed.
Broken hoses or oil lines	Repair/Replace any broken hoses or oil lines.
Loose or broken wires	Repair/Replace any loose or broken wires.

*If none of the above caused the shutdown, restart the engine and observe the engine oil pressure, engine water temperature, and compressor discharge temperature and pressure. If it is found that low engine oil pressure or high engine water temperature is causing the shutdown, refer to the Engine Manufacturer's manual.

6.3 DISCHARGE PRESSURE IS TOO LOW

POSSIBLE CAUSE	ACTION
Start/Run valve in the START position	Move the Start/Run valve to the RUN position and retest.
Too much air demand	Add additional compressor to handle the demand or decrease the air demand.
Service valve open	Close service valve and retest.
Regulator valve faulty or mis-adjusted	Properly adjust the regulator. Rebuild/replace the regulator valve if necessary.
Service line leaks	Repair any leaks found and retest.
Compressor inlet air filter restricted	Replace the air filter and reset.

6.4

DISCHARGE PRESSURE IS TOO HIGH OR RELIEF VALVE BLOWS

POSSIBLE CAUSE	ACTION
Regulator valve faulty or mis-adjusted	Properly adjust the regulator. Rebuild/replace the regulator if necessary.
Inlet valve not closing properly	Check the white sealing ring for the poppet valve, to ensure it is intact and not damaged.
Ice or debris in control lines	Clean debris from the control lines. Thaw out the control lines to remove the ice buildup. Optional Heater Kit available—consult factory for part number. Direct the lines so there is a low point to drain any condensate.
Pressure relief valve faulty	Replace the faulty relief valve.
Oil separator plugged	Replace the oil separator.
Inlet valve leaks at base	Replace O-ring.
Compressor shaft seal leaking	Replace the compressor shaft seal and retest.

6.5

RELIEF VALVE BLOWS WITH THROTTLE LEVER IN IDLE POSITION

POSSIBLE CAUSE	ACTION
Inlet valve not closing properly	Check the white sealing ring for the poppet valve, to ensure it is intact and not damaged. (185–375 CFM compressors) Rebuild/replace valve.

6.6

PRESSURE DOES NOT BLOW DOWN AFTER SHUTDOWN

POSSIBLE CAUSE	ACTION
Automatic blowdown valve may be faulty	Check operation of the automatic blowdown valve. Replace if necessary.
Air line from inlet valve or sump to blowdown valve may be restricted	Verify the pilot signal is reaching the automatic blowdown valve. Verify the blowdown valve is plumbed correctly.

6.7

COMPRESSOR OIL LEVEL IS DECREASING EXCESSIVELY

POSSIBLE CAUSE	ACTION
Oil line leaking	Repair or replace any leaking lines and retest.
Oil cooler leaking	Repair or replace the leaking oil cooler and retest.
Compressor shaft seal leaking	Replace the compressor shaft seal and retest.
Oil in service line	See “6.8 Oil in Service Line” section.

6.8

OIL IN SERVICE LINE

POSSIBLE CAUSE	ACTION
Oil return line plugged or restricted	Remove the oil return line and clean.
Separator element plugged or damaged	Replace the separator element and change compressor oil.
Discharge pressure below 90 psi	The air demand may be too much. Add compressors or decrease the demand. Adjust the discharge pressure above 90 psi. Check MPV operation; rebuild/replace as needed.
Condensation in sump tank	Drain condensation from sump tank.

6.9

ENGINE DOES NOT ACCELERATE OR WILL NOT MAINTAIN FULL LOAD SPEED

POSSIBLE CAUSE	ACTION
Compressor discharge pressure too high	Adjust the pressure to the maximum operating pressure for the machine.
Engine problem	Have an authorized engine repair facility inspect the engine.
Operating above maximum altitude rating of engine	Refer to Engine Manufacturer's recommendation on maximum altitude.
Engine fault codes present	Machine not out of warm-up mode; allow machine to complete warm-up.

6.10

SEPARATOR PLUGGING

POSSIBLE CAUSE	ACTION
Dirt and dust blockage in air inlet filters	Replace the air inlet filters.
Check compressor oil filter element	Replace the compressor oil and filter if necessary.

If the separator element has to be replaced frequently because it is plugging up, it is an indication that foreign material may be entering the compressor inlet or the compressor oil is breaking down. Compressor oil can break down prematurely for a number of reasons:

- » Extreme operating temperature
- » Failure to drain condensate from oil sump
- » Using the incorrect type of oil
- » Mixing different types of oil
- » Prolonged operation at extreme ambient temperatures
- » Foreign material, gases or vapors entering compressor inlet

6.11

ENGINE SPEED CONTROL DOES NOT CHANGE TO IDLE SPEED WITH SERVICE VALVES CLOSED

POSSIBLE CAUSE	ACTION
Faulty pressure transducer	Replace pressure transducer.
Faulty or broken wires to SPEC or pressure transducer	Fix or replace broken wires.
Faulty SPEC	Replace the SPEC or flash new program.

6.12

ENGINE SPEED CONTROL DOES NOT CHANGE TO FULL SPEED WITH AIR DEMAND

POSSIBLE CAUSE	ACTION
Start/Run valve is positioned in START instead of RUN	Move the Start/Run valve to the RUN position.
Faulty pressure transducer	Replace pressure transducer.
Faulty or broken wires to SPEC or pressure transducer	Fix/replace broken wires.
Faulty SPEC	Replace the SPEC or flash new program.
Engine fault codes present	Machine not out of warm-up mode; allow machine to complete warm-up.

6.13

COMPRESSOR OIL LEAKING IN CONTROL LINES/ORIFICES

POSSIBLE CAUSE	ACTION
Compressor oil level in sump tank too full	Check and adjust compressor oil as needed.
Oil return line (scavenger tube) plugged or restricted	Remove the oil return line and clean.
Separator element plugged or damaged	Replace the separator element and change compressor oil.
High compressor discharge temperature	Check the compressor oil level; add oil as needed. Clean the oil cooler. Check the fan belt. Adjust or replace as needed. Check thermal bypass valve (compressor oil thermostat). Change compressor oil and oil filter element. Clean the oil cooler internally.
Discharge pressure below 90 psi	The air demand may be too much. Add compressors or decrease the demand. Adjust the discharge pressure above 90 psi. Check MVP operation, rebuild/replace as needed.
Diaphragm in recirculation valve ruptured	Inspect the diaphragm, rebuild/replace as needed.
Condensation in sump tank	Drain condensation from sump tank.

Sullivan

Palatek

AIR COMPRESSORS

1201 West US Highway 20
Michigan City, Indiana 46360

Phone: 219.874.2497

Fax: 219.809.0203

info@palatek.com

www.sullivan-palatek.com

